

V-Series
Rigging manual 1.10 en

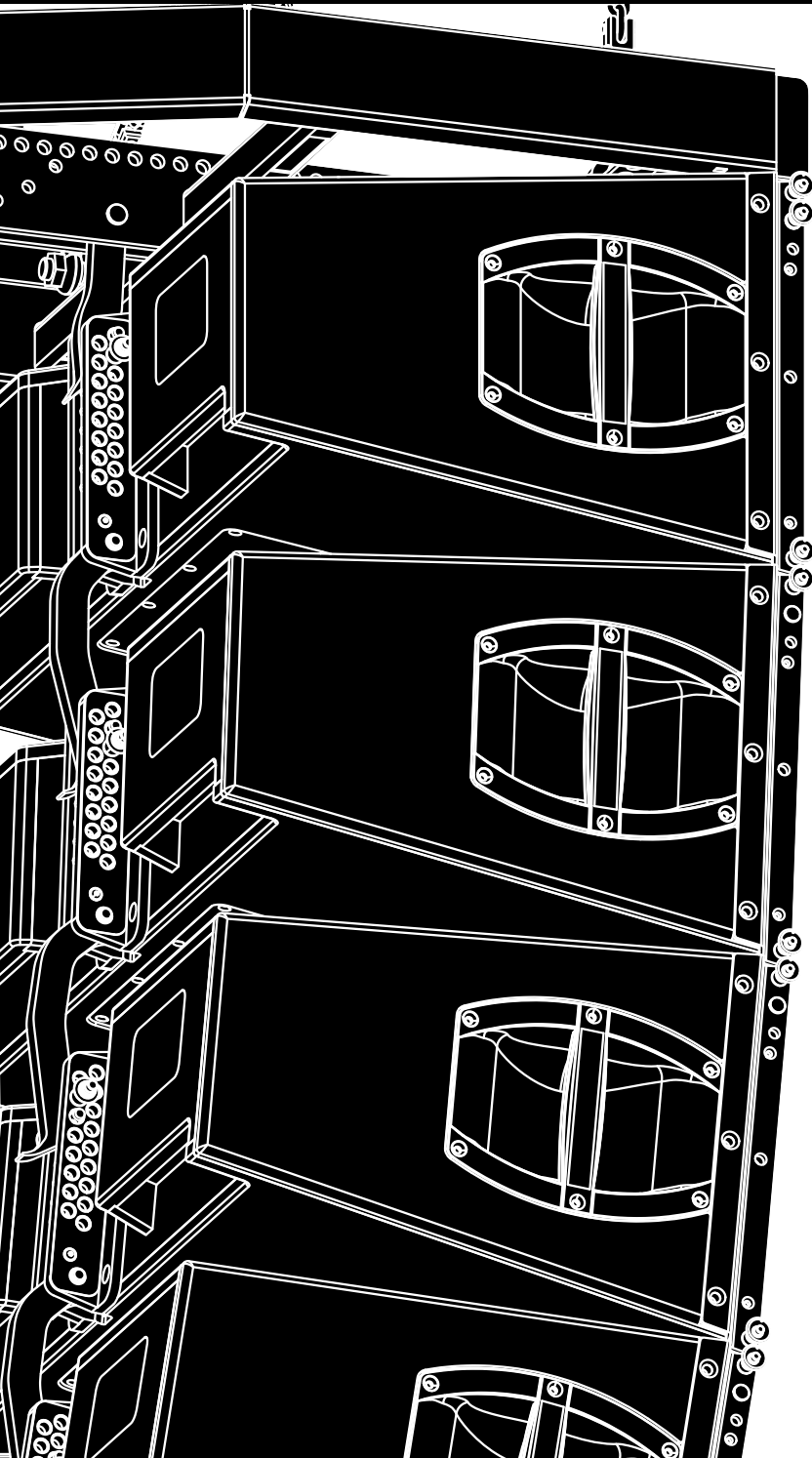

General information

V-Series Rigging manual

Version: 1.10 en, 10/2016, D2702.EN .01

Copyright © 2016 by d&b audiotechnik GmbH; all rights reserved.

Keep this manual with the product or in a safe place so that it is available for future reference.

When reselling this product, hand over this manual to the new owner.

If you supply d&b products, please draw the attention of your customers to this manual. Enclose the relevant manuals with the systems. If you require additional manuals for this purpose, you can order them from d&b.

d&b audiotechnik GmbH
Eugen-Adolff-Strasse 134, D-71522 Backnang, Germany
T +49-7191-9669-0, F +49-7191-95 00 00
docadmin@dbaudio.com, www.dbaudio.com

1. Safety	4
1.1. Intended use.....	4
1.2. General safety.....	4
1.3. Load capacity/System safety.....	4
1.4. Operational safety.....	5
1.5. d&b ArrayCalc simulation software / TI 385.....	5
2. V-Series rigging concept	6
2.1. Z5380 V Flying frame - Scope of supply.....	6
2.2. Z5382 V Safety chainset.....	10
2.3. Z5381 V Hoist connector chain option.....	10
2.4. Ring cotters.....	11
2.5. Locking pins.....	12
2.6. Load adapter.....	13
2.7. Suspension of the Flying frame.....	14
2.8. Secondary safety.....	16
2.9. Splay link of the frame.....	17
2.10. Cable pick.....	18
2.11. Cabinet rigging mechanism.....	19
3. V-Series arrays and assembly	21
3.1. Setup preparation.....	22
3.2. Flown arrays.....	22
3.3. V Touring cart assembly.....	30
3.4. Ground stacks.....	35
4. Safety and system checks	39
4.1. Mechanical setup.....	39
4.2. Wiring.....	39
5. Hoisting and securing the array	40
5.1. Hoisting the array.....	40
5.2. Securing the array.....	40
6. Derigging	41
6.1. General.....	41
6.2. Touring cart disassembly.....	41
7. Care and maintenance / Disposal	43
7.1. Transport / Storing.....	43
7.2. Visual and functional inspection.....	43
7.3. Disposal.....	44
8. Manufacturer's declaration	45

1.1. Intended use

The V-Series rigging components (Flying frame, Load adapter, Locking pins) must only be used in conjunction with d&b V-Series loudspeakers as described in this manual.

1.2. General safety

Installation and setup should only be carried out by qualified and authorized personnel observing the valid national Rules for the Prevention of Accidents (RPA).

It is the responsibility of the person installing the assembly to ensure that the suspension/fixing points are suitable for the intended use.

Always carry out a visual and functional inspection of the items before use. In case there is any doubt as to the proper functioning and safety of the items, these must be withdrawn from use immediately.

Please also refer to ⇒ Chapter 7. "Care and maintenance / Disposal" on page 43.

1.3. Load capacity/System safety

NOTICE!

The Z5380 V Flying frame is designed to support a total system weight of 860 kg (1896 lb) – WLL.

This allows the suspension of a maximum of 24 x V-TOP cabinets or a SUB column consisting of a maximum of 10 x V-SUB cabinets.

The rigging components allow arrays of up to 10 x V-TOP cabinets with a total system weight of 340 kg (750 lb) to be flown in any vertical splay angle configuration between the cabinets.

For any other array configuration the load conditions within the array have to be checked using the ⇒ d&b ArrayCalc simulation software.

1.3.1. Wind loads



WARNING!

Potential risk of personal injury and material damage!

Flying loudspeakers overhead at wind forces higher than 6 bft (22-27 knots, 39-49 km/h, 25-31 mph) is not recommended.

If the wind force exceeds 8 bft (34-40 knots, 62-74 km/h, 39-46 mph):

- Make sure that no person remains in the vicinity of the array.
 - Lower and secure the array.
-



1.4. Operational safety

The assembly should always be carried out by two persons.

During assembly pay attention to the possible risk of crushing. Wear suitable protective clothing.

Observe all instructions given on the respective instruction labels of the rigging components (Flying frame, Load adapters), Touring carts and loudspeaker cabinets.

When chain hoists are in operation ensure that there is nobody directly underneath or in the vicinity of the load.

Do not under any circumstances climb on the array.

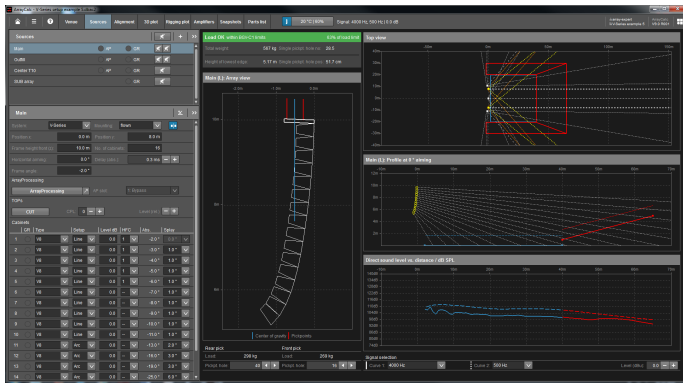

d&b ArrayCalc

1.5. d&b ArrayCalc simulation software / TI 385

For both safety and acoustic reasons, d&b line arrays must be designed using the d&b ArrayCalc simulation software. The software is available as a native stand-alone application for both Microsoft Windows and Mac OS X operating systems and can be downloaded at www.dbaudio.com.

Detailed information on how to use and operate ArrayCalc is provided by the Help system of the software. To access the Help system, press F1 or select the Help button () from the ArrayCalc toolbar. This will launch the HelpViewer which provides an overview of the program as well as a search function and direct access to the related topics.

In addition, ArrayCalc will provide you with typical array configurations within the permitted load limits and will help you get familiar with the mechanical load conditions and limitations.

Further information on line array design can be found in "TI 385 d&b Line array design, ArrayCalc". The TI is supplied with the software or can be downloaded from the d&b website at www.dbaudio.com.

We also recommend you to attend the regularly hosted d&b Line array training seminars. Further information regarding the d&b seminars and a seminar schedule can also be found on the d&b website at www.dbaudio.com.

2. V-Series rigging concept

2.1. Z5380 V Flying frame - Scope of supply

Please verify the shipment for completeness and proper condition of the items.

The Z5380 V Flying frame is equipped and supplied with the following rigging components:

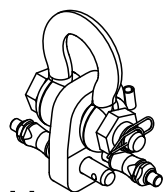

[5]

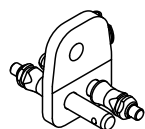

[6]

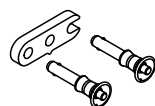

[7]

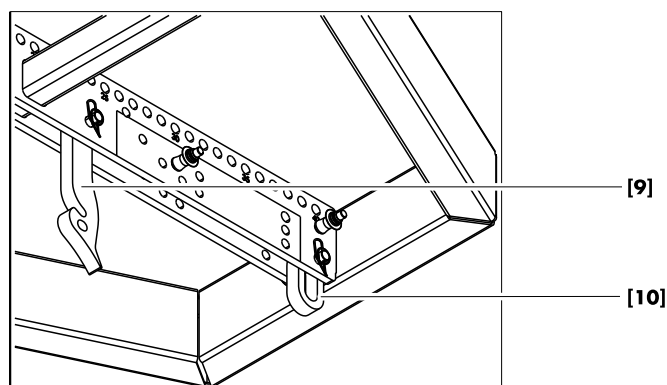
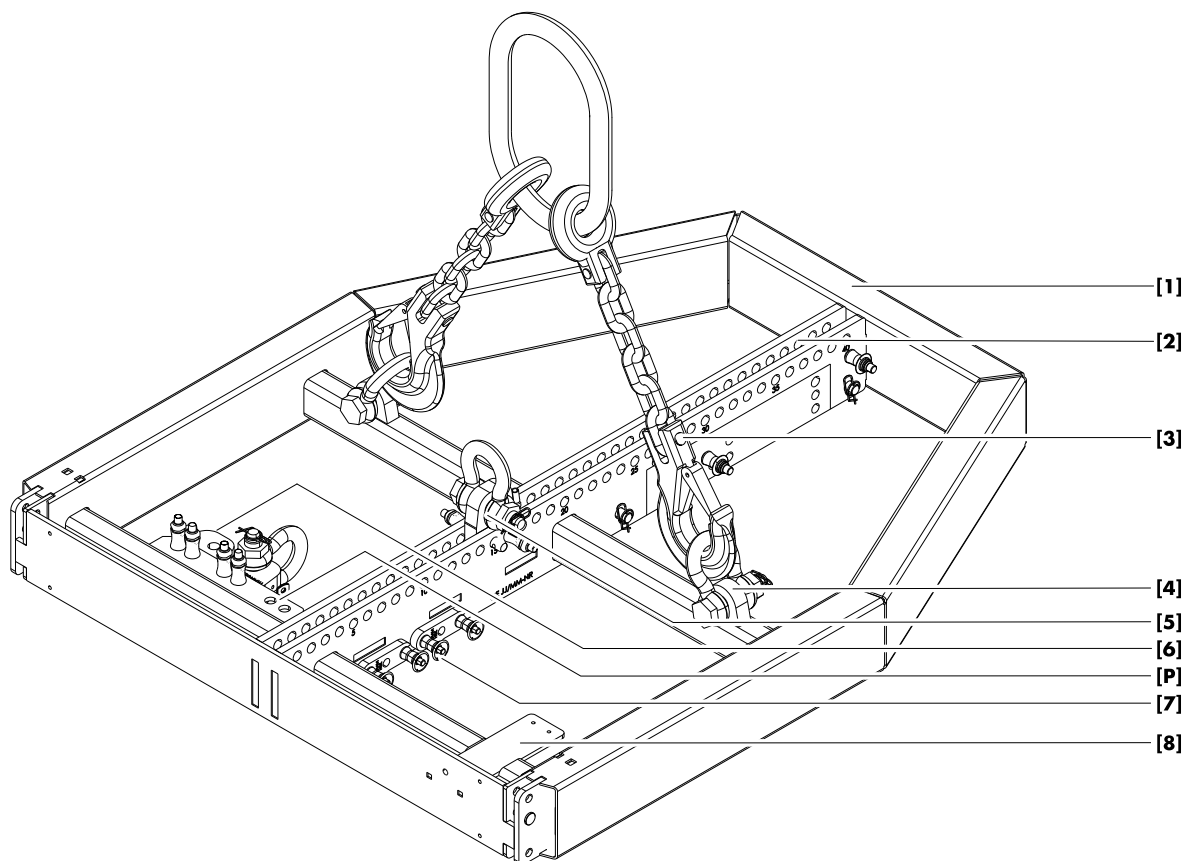

Z5380 V Flying frame top and bottom views

Pos.	Component	Description
[1]	Z5380 V Flying frame	<p>The Z5380 V Flying frame is designed to support arrays consisting of:</p> <ul style="list-style-type: none"> - Z0515/Z0516, V8/V12. Weight: 34 kg (75 lb). - Z0518 V-SUB. Weight: 64 kg (141 lb). <p>The weight of the V Flying frame including all rigging components is 25.4 kg (56 lb).</p>
[2]	Flying frame center bar	
[3]	Z5382 V Safety chainset	The Z5382 V Safety chainset is supplied with the Flying frame.
[4]	Safety point(s)	The Flying frame is fitted with two safety points each equipped with a 2 t shackle to attach a secondary safety device using the enclosed V Safety chainset (refer to ⇒ Chapter 2.8. "Secondary safety" on page 16).
[5]	V Load adapter	<p>The Flying frame is supplied with two Load adapter to allow single or dual pickpoint operation. Each Load adapter is supplied with a pair of Locking pins 10 mm and a 2 t shackle (refer to ⇒ Chapter 2.6. "Load adapter" on page 13).</p> <p>In addition, the enclosed V Load adapter Rota Clamp allows single pickpoint operation in combination with the d&b Z5147 Rota clamp for a maximum system weight of up to 500 kg/ 1100 lb (also refer to ⇒ Chapter 2.6. "Load adapter" on page 13).</p> <p>During transport the Load adapters should be stored at their park positions (refer to ⇒ Chapter 2.6. "Load adapter" ⇒ "Fixing the Load adapter at Park position" on page 13).</p>
[6]	V Load adapter Rota Clamp	
[P]	Park position	
[7]	Front link (Frame)	<p>Two additional Front links together with a pair of Locking pins 8 mm each are supplied with the Flying frame. They are used to mount V-Series cabinets on top of the Flying frame for the following setups:</p> <ul style="list-style-type: none"> - Mixed V-Series array with V-SUB cabinets at the top of the column (refer to ⇒ Chapter 3.2.3. "Mixed array" on page 28). - V-Series ground stack with the Flying frame as ground support (refer to ⇒ Chapter 3.4. "Ground stacks" on page 35).
[8]	Mounting plate	An additional mounting plate is provided to accept industry standard inclinometers such as the Teqas LAP-TEQ line array positioning tool.
[9]	Splay link (Frame)	<p>In connection with the Front links of the V-Series loudspeaker cabinets, the Splay link of the frame is used to attach the first cabinet to the frame. By default, the Splay link of the frame is fixed at «POSITION V8/V12». To accept V-SUB cabinets, the Splay link can be moved to «POSITION V-SUB» (refer to ⇒ Chapter 2.9. "Splay link of the frame" on page 17).</p> <p>During transport the Splay link should be folded back into its park position and secured by the respective Locking pin.</p>
[10]	Cable pick	An O-ring at the rear bottom of the frame slides out when releasing the respective Locking pin to attach a cable pick (refer to ⇒ Chapter 2.10. "Cable pick" on page 18).

2.1.1. Flying frame instruction label

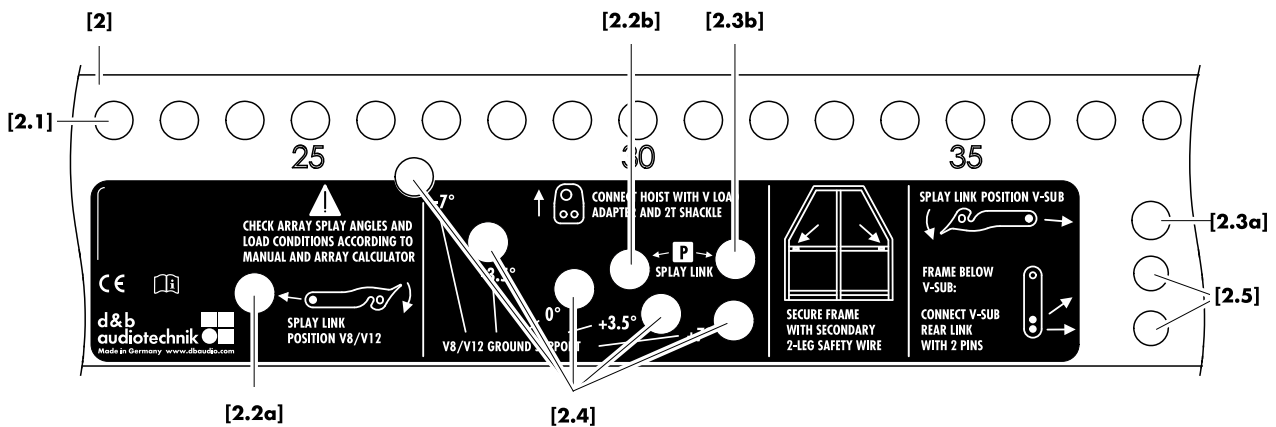
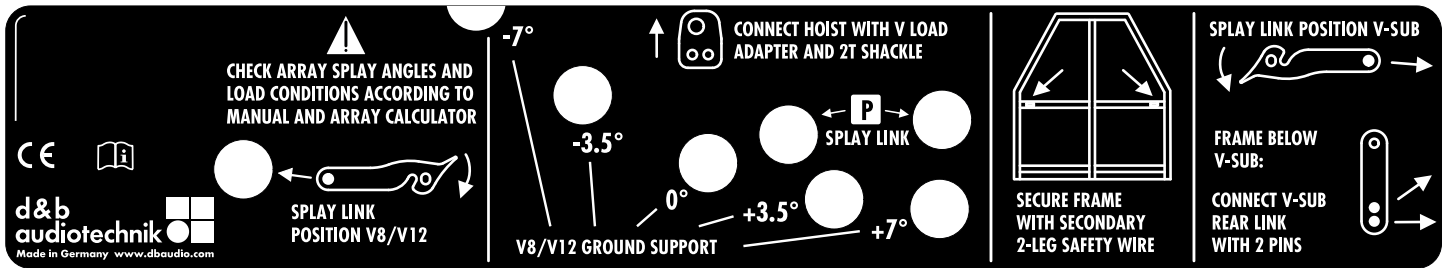

Pos.	Description
[2]	Center bar of the Flying frame with user instruction label.
[2.1]	Main hole grid at the top of the center bar with a total of 40 holes numbered with an increment of five. Using the V Load adapters the Flying frame can be suspended from one or two pickpoints (refer to ⇒ Chapter 2.6. "Load adapter" on page 13 and ⇒ Chapter 2.7. "Suspension of the Flying frame" on page 14).
[2.2a]	Fixing point for the frame's Splay link in «POSITION V8/V12».
[2.2b]	The additional hole is used to fix the Splay link at park position (P) using the respective Locking pin (refer to ⇒ Chapter 2.9. "Splay link of the frame" on page 17).
[2.3a]	Fixing point for the frame's Splay link in «POSITION V-SUB».
[2.3b]	The additional hole is used to fix the Splay link at park position (P) using the respective Locking pin (refer to ⇒ Chapter 2.9. "Splay link of the frame" on page 17).
[2.4]	Hole grid ground stack: when V8/V12 cabinets are attached to the top of the frame, this hole grid indicates the possible settings of -7°, -3.5°, 0°, +3.5° or +7° for the Splay link of the first (bottom) cabinet (refer to ⇒ Chapter 3.4. "Ground stacks" on page 35).
[2.5]	If the Flying frame is fitted below a V-SUB cabinet (Mixed V-Series array with V-SUB cabinets at the top of the column), these two holes are used to fix the Rear link of the "last" V-SUB cabinet to the frame using the Locking pin of the respective cabinet and the Locking pin of the Cable pick (refer to ⇒ Chapter 3.2.3. "Mixed array", ⇒ step "2. Attach the assembly to the frame" on page 28).

2.1.2. Dimensional drawing

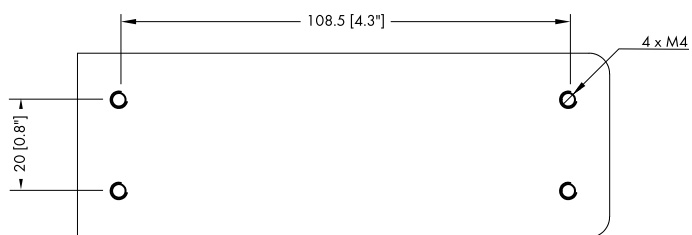
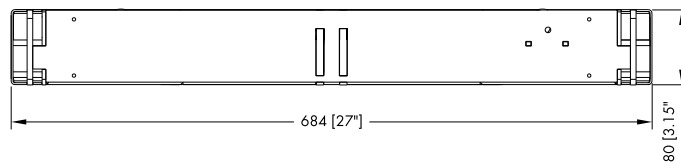

**Z5380 V Flying frame laser/inclinometer mounting plate [8]
dimensions in mm [inch]**

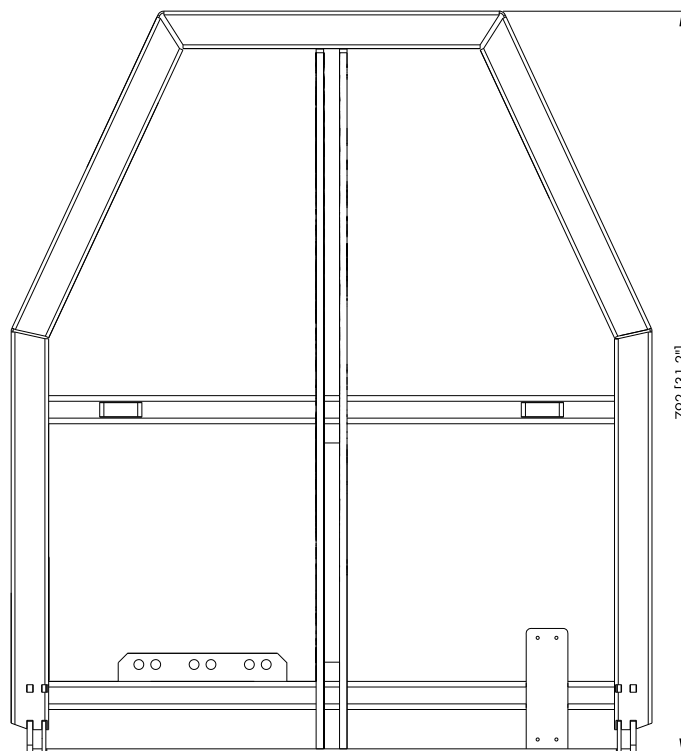

Z5380 V Flying frame dimensions in mm [inch]

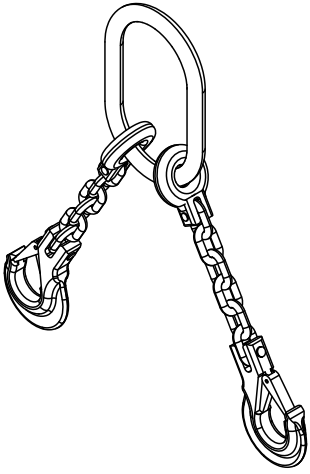

2.2. Z5382 V Safety chainset

The Z5382 V Safety chainset is supplied with the V Flying frame and is used as a secondary safety device. Please also refer to ⇒ Chapter 2.8. "Secondary safety" on page 16.

Specification

Lifting chain (DIN EN 818)	2-leg, 8 mm
Grade.....	8
Nominal length incl. hooks	416 mm (16.4")
Maximum sling angle β_{Max}	60°
Load rating	3.35 t (β : 0° - 45°)
.....	2.5 t (β : 46° - 60°)

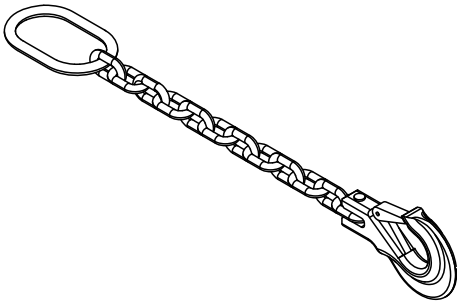

2.3. Z5381 V Hoist connector chain option

The Z5381 V Hoist connector chain is used to connect the lifting motor(s) to the V Flying frame using the 2 t shackle which is attached to the V Load adapter. Its length of 53 cm (21") allows enough space for the hang of most 2 t motor chain containers and avoids any impact on the vertical balance of the array when suspended from a single pickpoint.

Specification

Lifting chain (DIN EN 818)	1-leg, 8 mm
Grade.....	8
Nominal length incl. hook	535 mm (21")
Load rating	2 t

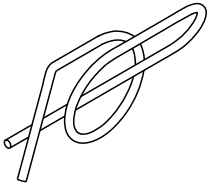

Ring cotter

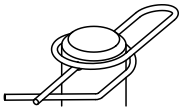

Ring cotter locked

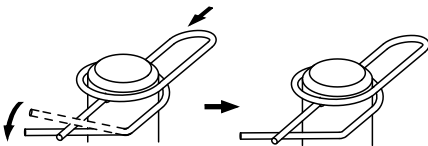
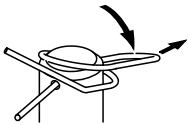
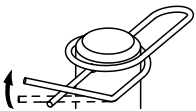

2.4. Ring cotters

In connection with the V-Series rigging system, ring cotters are used for the following items to prevent the respective item from slackening and/or loosening:

- Fixing bolt of the SUB cabinet's Rear link.
- Fixing bolt of the frame's Splay link and cable pick.
- Fixing bolt of the 2 t shackles attached to the Load adapters and safety points of the Flying frame.
- Fixing bolt of the Z5147 Rota clamp.

Function of the ring cotter

By default, the ring cotters are "locked" to prevent them from loosening.

For modification reasons such as altering the position of the frame's Splay link or exchanging a shackle, it may be necessary to temporarily remove the cotter and reattach it afterwards.

Note: Please also refer to ⇒ Chapter 7. "Care and maintenance / Disposal", ⇒ section 7.2. "Visual and functional inspection", ⇒ "Ring cotters" on page 43.

For this purpose proceed as follows:

1. **Unlock**

Unlock the ring cotter by pushing up the front wire loop over the straight wire shaft.

2. **Release and remove**

Push down the rear wire loop until the ring cotter snaps over the edge of the bolt and remove the ring cotter.

3. **Refit and lock**

Refit the ring cotter by pushing the straight wire shaft through the hole and pressing the front wire loop underneath the straight wire shaft.

2.5. Locking pins



WARNING!

Potential risk of personal injury and/or damage to material!

The steel wires between the Locking pins of the cabinets and rigging components are not intended to carry any load. The cabinet's weight must only be carried by the Front and Splay/Rear links in conjunction with the front and rear rigging strands of the loudspeaker cabinets and the Flying frame.

Ensure all Locking pins are fully inserted and securely locked before lifting any load.

The V-Series loudspeaker cabinets and flying frame are equipped with three types of Locking pins:

Type [A] Locking pin 10 x 35 mm.
Used for the Load adapters.

Type [B] Locking pin 9 x 40 mm.
Used for the cabinets' Splay/Rear links and for the frame's Splay link and Cable pick.

Type [C] Locking pin 8 x 23 mm.
Used for the Front links of the loudspeaker cabinets and the frame.

Note: The Locking pins are undetachably attached to the different rigging components on the cabinet and the frame using steel wires.

Throughout this manual these steel wires are not shown in the corresponding illustrations.

Functionality (Quick lock mechanism)

The quick lock mechanism applies to all types of Locking pins listed above. Proceed as follows:

1. Press the button to **release** the locking mechanism (← [r]).
2. Remove the Locking pin through the respective link or socket.
3. Insert the Locking pin through the respective link or socket until it is fixed in place.
4. Release the button to **lock** the pin (→ [l]).
5. Recheck the Locking pin is securely locked by briefly pulling the Locking pin towards you.

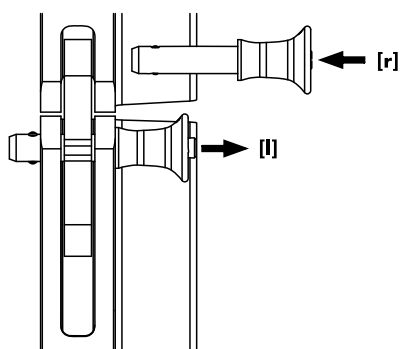
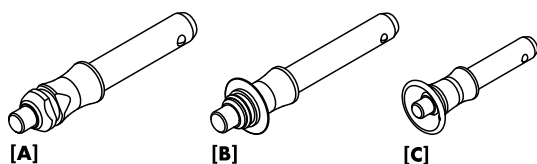

Locking pin assembly

Shown with pin type [C]

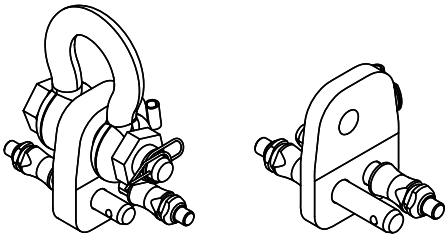

V-Series Load adapter
Type 1/Type 2

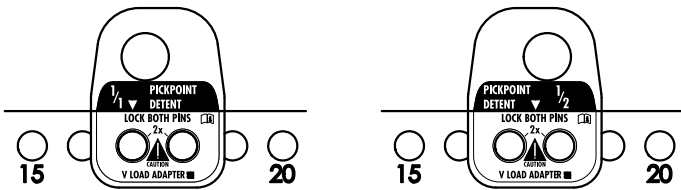

Direction of the Load adapter for:

Left: Full grid (1/1 PICKPOINT DETENT), shown: Hole 17

Right: Half grid (1/2 PICKPOINT DETENT), shown: Hole 17.5

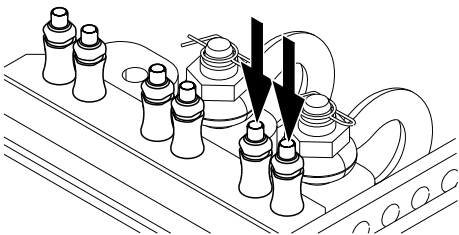
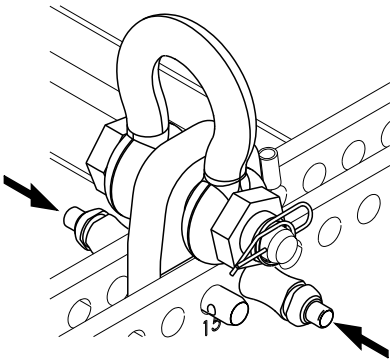

2.6. Load adapter

The Flying frame is supplied with two different types of load adapters:

Type 1: 2 x V Load adapter, allowing either single or dual pickpoint operation.

Type 2: 1 x V Load adapter Rota Clamp, allowing single pickpoint operation in combination with the d&b Z5147 Rota clamp for a maximum system weight of up to 500 kg /1100 lb.

Both types allow for a full grid (1/1 PICKPOINT DETENT) or a half grid (1/2 PICKPOINT DETENT) setting depending on the direction of attachment to the frame's center bar.

The frame's hole index marked on one side of the center bar is the reference for the direction of the Load adapter.

As an example, the graphics opposite show hole positions 17 and 17.5 in connection with the V Load adapter.

As an example, the graphics opposite show hole positions 17 and 17.5 in connection with the Y Load adapter.

Note: The same applies to the V Load adapter Rota Clamp.

Attaching the Load adapter to the Flying frame

! WARNING!
Potential risk of personal injury and/or damage to material!

Before attaching the Load adapter, check the 2 t. shackle is properly fitted to the Load adapter and secured with a locked ring cotter.

Ensure the Load adapter is properly attached to the center bar of the frame and both Locking pins are inserted and locked securely before lifting the array.

The Load adapter is attached to the center bar of the Flying frame and fixed using its two Locking pins 10 mm.

Note: It is advisable to insert the Locking pins opposite each other as shown in the graphic opposite.

Fixing the Load adapter at Park position

During transport the Load adapters should be stored at their park positions **[P]**.

For this purpose, insert both Locking pins of each Load adapter in the same direction from the top, as shown in the graphic opposite.

2.7. Suspension of the Flying frame

The suspension of the V Flying frame is carried out using one or two V Load adapter(s), depending on the chosen type of suspension (Single or Dual pickpoint operation).

The Load adapters are attached to the center bar of the Flying frame and fixed using the two Locking pins of each adapter as described in the previous section ⇒ 2.6. Load adapter ⇒ Attaching the Load adapter to the Flying frame on page 13.

2.7.1. Single pickpoint operation

With "Single pickpoint operation" the position of the V Load adapter defines the vertical aiming of the entire array. The corresponding hole position is calculated using ArrayCalc.

Note: The target angle of the entire array is achieved when the array is fully set up and hoisted as intended.

Attachment

1. Choose the appropriate hole position on the center bar according to the ArrayCalc calculation and attach the Load adapter correspondingly.
⇒ If ArrayCalc displays a half numbered hole setting (half grid) turn the Load adapter correspondingly.
2. Attach the Hoist connector chain or motor hook to the shackle of the Load adapter.

2.7.2. Z5147 Rota clamp option

Alternatively, a V-Series array with a total system weight of up to 500 kg (1100 lb) can be suspended and horizontally aligned from a single flying point using the d&b Z5147 Rota clamp. The clamp allows the load to be attached to overhead bars or truss with a tube diameter of up to 51 mm (2").

The corresponding hole position is calculated using ArrayCalc.

Attachment

1. Choose the appropriate hole position on the center bar according to the ArrayCalc calculation and attach the Load adapter Rota clamp correspondingly.
⇒ If ArrayCalc displays a half numbered hole setting (half grid) turn the Load adapter correspondingly.
2. Attach the Rota clamp to the Load adapter.

Note: Please observe the relevant mounting instructions which are enclosed with the Rota clamp.

Single pickpt. hole no: 17

Single pickpt. hole pos: 30.8 cm

ArrayCalc Single pickpoint

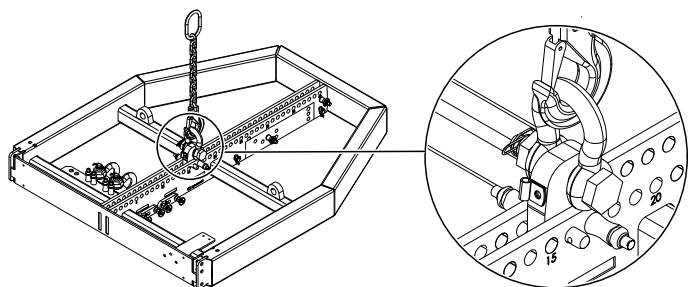

Single pickpt. hole no: 17

Single pickpt. hole pos: 30.8 cm

ArrayCalc Single pickpoint

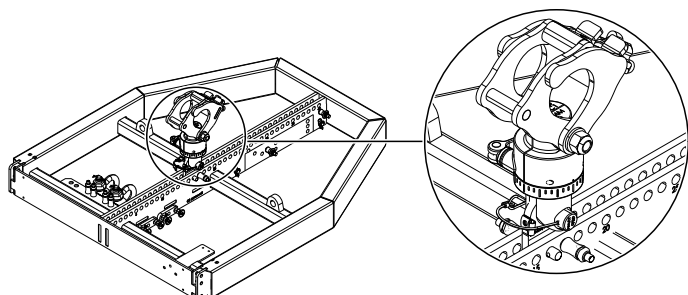

Rear pick	Front pick
Load: 152 kg	Load: 145 kg
Pickpt. hole: 40 ◀ ▶	Pickpt. hole: 1 ◀ ▶

ArrayCalc Dual pickpoint

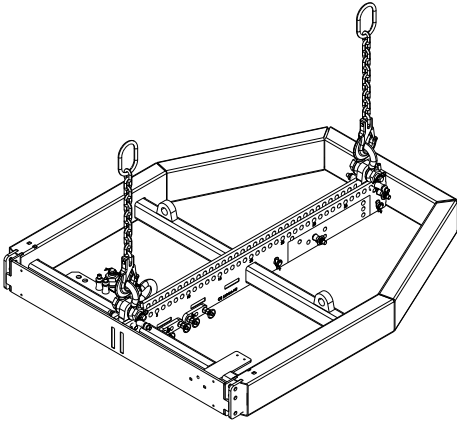

2.7.3. Dual pickpoint operation

With "Dual pickpoint operation" the vertical aiming of the array is set by trimming the hoist motors after the array has been fully assembled and lifted to its operating position. The corresponding hole positions are calculated using ArrayCalc.

Attachment

1. Choose the appropriate hole positions for the Front and Rearpick on the Flying frame center bar according to the ArrayCalc calculation and attach the Load adapters correspondingly (Direction: Full grid 1/1 pickpoint Detent).
2. Connect the Hoist connector chains or motor hooks to the shackles of the Load adapters.

2.8. Secondary safety



WARNING!

Potential risk of personal injury and/or damage to material!

The secondary safety suspension must be independent of the primary suspension points and capable of carrying the total system weight.

The additional safety device must be mounted in a way that the array is caught by the safety device without any drop and swing in the event that the primary suspension fails.

The Z5380 V Flying frame is equipped with two safety points **[4]** fitted with two 2 t shackles to accept a secondary safety device. We recommend the use of the d&b Z5382 V Safety chainset which is supplied with the Flying frame.

Assembly

The two legs of the V Safety chainset and the distance **[d]** between the two safety points **[4]** of the frame's tie bar form an equilateral triangle maintaining the maximum sling angle (β_{Max}) of 60° .

1. Before attaching the safety device ensure the two 2 t shackles **[S]** are properly fitted to the frame's safety points **[4]** and secured against loosening using a locked ring cotter **[C]** as shown in the graphic opposite.
2. Attach the Safety chain and ensure the chains are not twisted and the hooks **[H]** are in the right direction as shown in the graphic opposite.

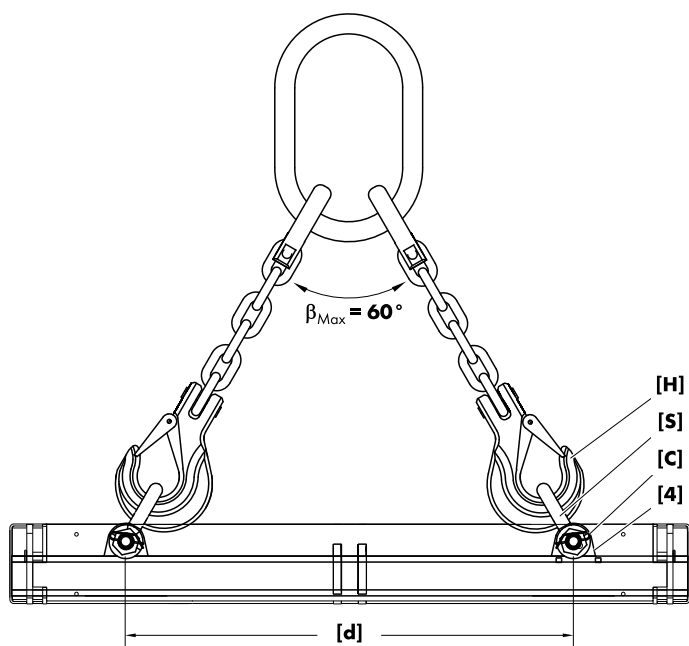

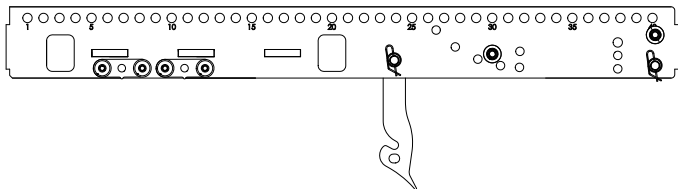

Splay link of the frame – «POSITION V8/V12»

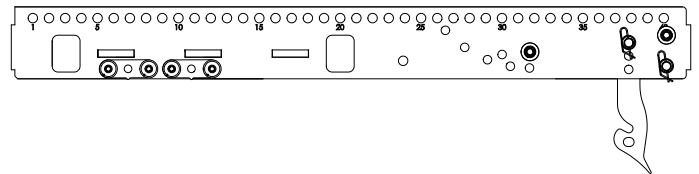

Splay link of the frame – «POSITION V-SUB»

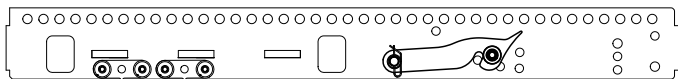

Splay link at park position – «POSITION V8/V12»

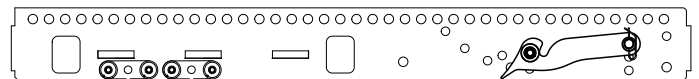

Splay link at park position – «POSITION V-SUB»

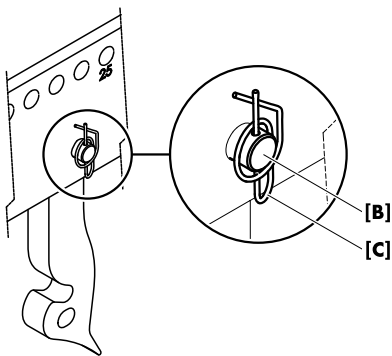

Changing the Splay link position

! WARNING!
Potential risk of personal injury and/or damage to material!

The fixing bolt **[B]** of the frame's Splay link bears the full load of the array.

It is essential that the bolt is fitted correctly and secured by a locked ring cotter **[C]**.

To change the Splay link position, proceed as follows:

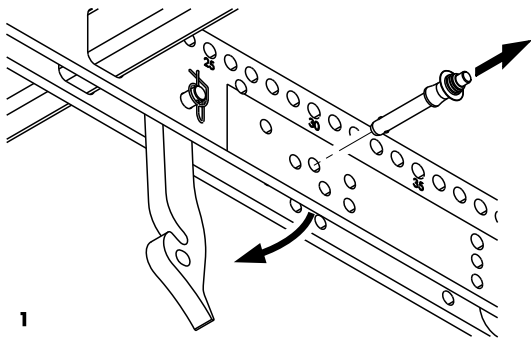

1. Release and remove the Locking pin of the Splay link at park position and fold out the Splay link.

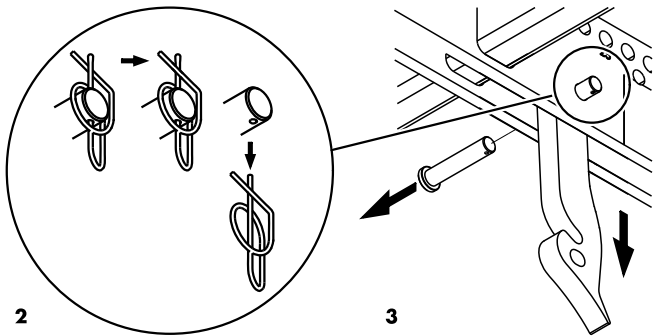

2. Unlock and remove the ring cotter of the fixing bolt.
3. Pull out the fixing bolt and remove the Splay link.

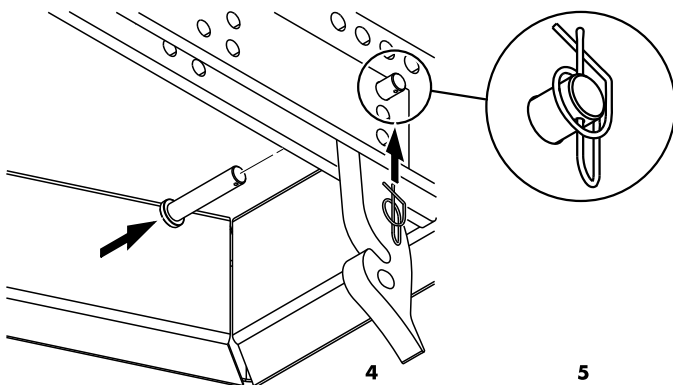

4. Attach the Splay link to its new position and insert the fixing bolt.
5. Secure the fixing bolt using the ring cotter and ensure the ring cotter is properly locked.

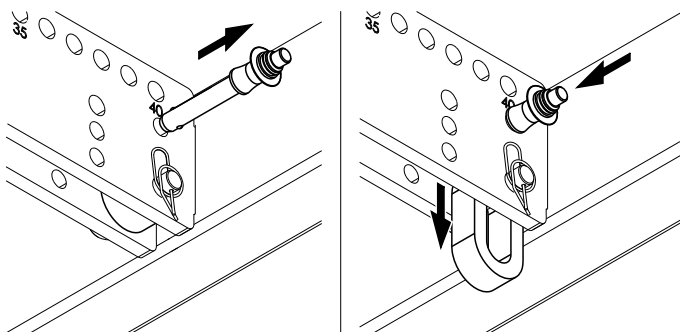

Cable pick

2.10. Cable pick

The Flying frame is equipped with an O-ring to allow the attachment of a cable pick. To prepare the attachment of the cable pick, proceed as follows:

1. Release the Locking pin holding the O-ring at park position.
2. Pull out the O-ring and reinsert the Locking pin.

2.11. Cabinet rigging mechanism

V-Series cabinets are mechanically connected to the V Flying frame and subsequent loudspeakers using the Front links attached to both sides of the cabinet front and the central Splay/Rear link at the rear of the cabinet.

All necessary rigging components are mounted to the cabinet and slide out when needed.

In principle, the Front link mechanism applies to both the V8/V12 and V-SUB cabinets.

2.11.1. Front link mechanism

V8/V12

1. Release both Locking pins and slide out the Front link.
2. Insert and lock one Locking pin to the upper hole to fix the link in place.

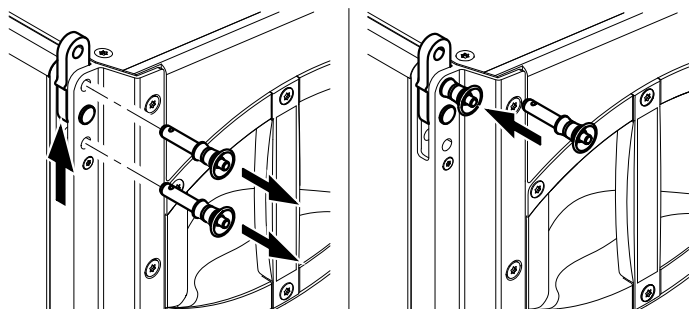

V8/V12 Front link mechanism

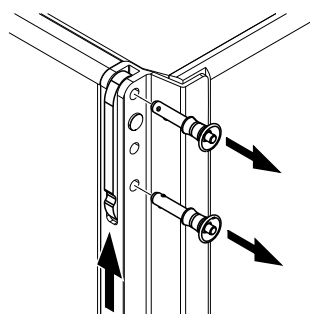

V-SUB Front link mechanism

V-SUB

The Front link mechanism of the SUB cabinets provides four different settings:

- a. SUB to Frame (\Rightarrow Fig. 1)
- b. SUB to SUB with 0° splay between the cabinets (\Rightarrow Fig. 2).
- c. SUB to SUB with 2.5° splay (free \Rightarrow Fig. 3) between the cabinets.
- d. SUB to SUB with 2.5° splay (blocked \Rightarrow Fig. 4) between the cabinets.
This setting is used to prevent the cabinets from folding up.

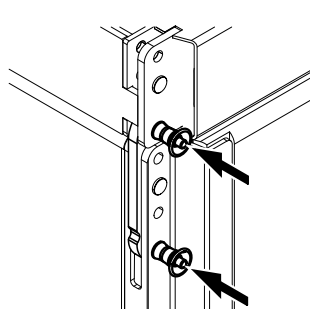

Fig. 1: SUB to Frame

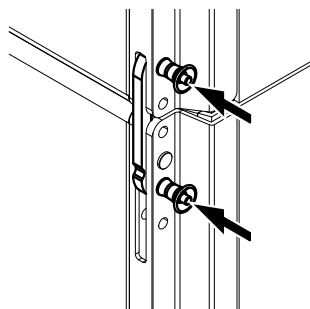

Fig. 2: SUB to SUB, 0° splay

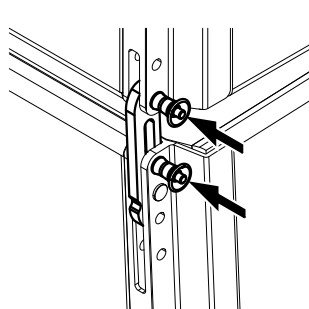

Fig. 3: SUB to SUB, 2.5° splay, free

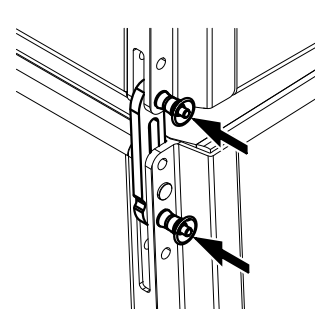
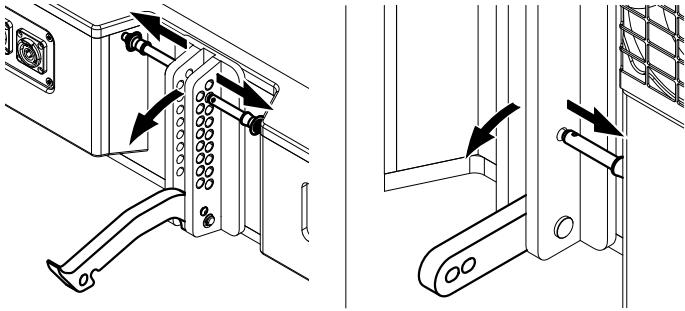

Fig. 4: SUB to SUB, 2.5° splay, blocked



Splay/Rear link mechanism

2.11.2. Splay/Rear link mechanism

Release the respective Locking pin(s) and fold out the Splay/Rear link.

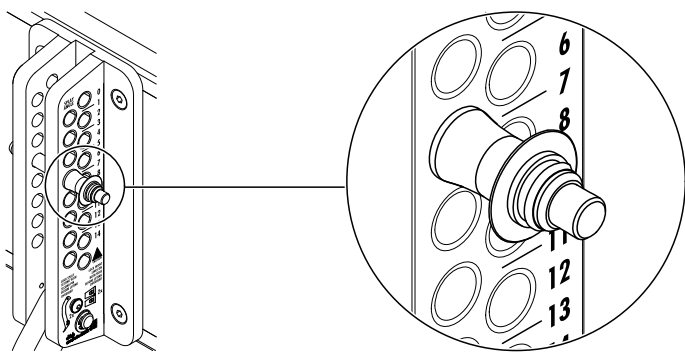

Preset splay angle (e.g. 7°)

2.11.3. Preset splay angles on V8/V12 cabinets

The splay angles between adjacent cabinets can be set in the range from 0° to 14° in 1° steps. The splay angles are set at the central rear rigging strands of the cabinets.

- Insert and lock the Locking pin to the respective hole.

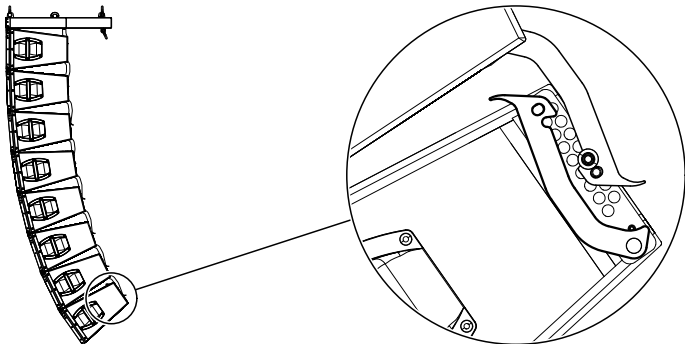

Park position V8/V12 Splay link

2.11.4. Park position V8/V12 Splay link

The Splay link of the last cabinet of an array may be kept in its park position.

Note: In this case, the lowest cabinet can be set to the following splay angles: 3°, 5° and 7° to 14°.

3. V-Series arrays and assembly

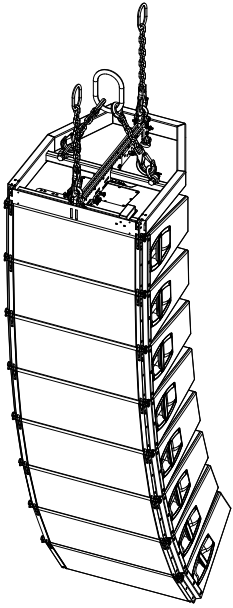

V8 Line array 8-deep, dual pickpoint operation, shown with:
 Z5381 V Hoist connector chain
 Z5382 V Safety chainset
 Refer to

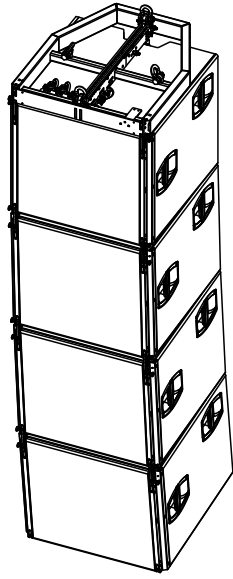

V-SUB column shown with 2.5° splay between the cabinets
 Refer to

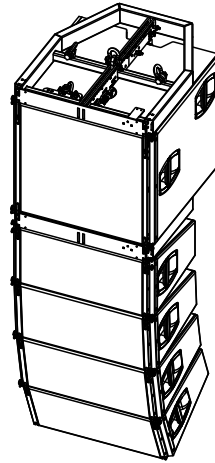

Mixed array with V-SUB at the top of the array
 Refer to

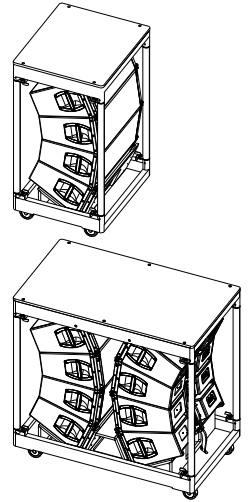

V Touring cart assembly
 Refer to ⇒ Chapter 3.3. "V Touring cart assembly" on page 30

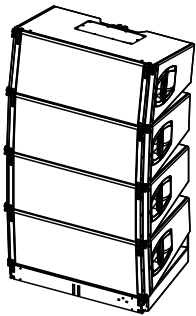

V8/V12 Ground stack
 Refer to

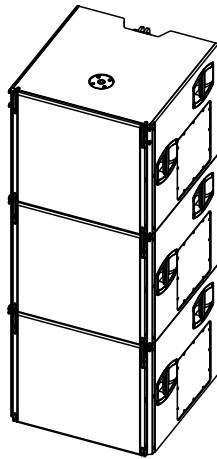

V-SUB Ground stack
 Refer to

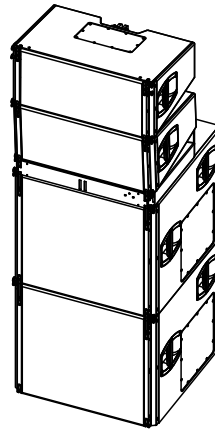

Mixed ground stack
 Refer to ⇒ Chapter 3.4.3. "Mixed ground stack" on page 38

3.1. Setup preparation

Check the acoustical and mechanical setup using ArrayCalc and prepare enough printouts for each array.

The plan enables the riggers to set up the suspension points, the securing points and the chain hoists.

When on site first:

- Clear the working areas and ensure there is enough space to set up and lift the array.
- Check that the hoists are exactly in the specified position.
- Ensure the chains are not twisted.

Inspections before setup

Before setup carry out a visual inspection of all system components for faults. This also includes the loudspeakers and in particular the rigging parts of the cabinets (Front and Splay/Rear links). Damaged components must be withdrawn from use immediately.

Please follow the instructions given in ⇒ Chapter 7. "Care and maintenance / Disposal" on page 43.

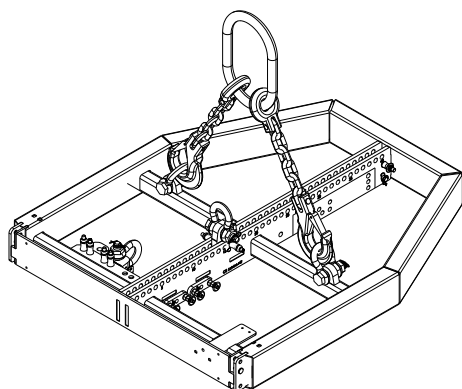

3.2. Flown arrays

Flown arrays are suspended using the Z5380 V Flying frame.

1. Suspend the Flying frame according to the chosen type of suspension as described in ⇒ Chapter 2.7. "Suspension of the Flying frame" on page 14.
2. At this point we recommend you to attach the secondary safety device using the Z5382 V Safety chainset as described in ⇒ Chapter 2.8. "Secondary safety" on page 16.
3. Prepare the cables and link cables according to the number of amplifier channels and cabinets used.

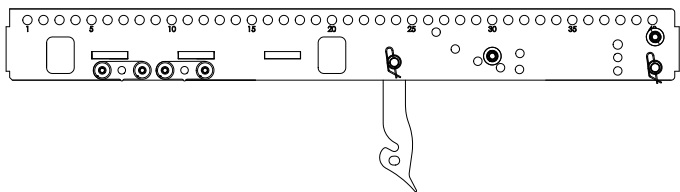

Splay link of the frame – «POSITION V8/V12»

3.2.1. V8/V12 Array

Preparations

For this type of setup the Splay link of the frame must be attached to «POSITION V8/V12». Check the position and alter it if necessary as described in ⇒ Chapter 2.9. "Splay link of the frame" ⇒ "Changing the Splay link position" on page 17.

1. Prepare the first cabinet

Prepare the Front and Splay links of the first cabinet as described in ⇒ Chapter 2.11. "Cabinet rigging mechanism" on page 19.

2. Attach the Flying frame to the first cabinet

1. Lower the frame onto the cabinet until the Front links fit into the slots at the front of the frame.
2. Insert and lock the second Locking pins of the cabinet's Front links on both sides.
3. Release the Locking pin that keeps the frame's Splay link in its park position.
4. Fold out the Splay link and reinsert the Locking pin.
5. On the rear rigging strand of the cabinet, insert and lock the first Locking pin of the cabinet in the [0°] hole.
6. Slightly lower the frame and fold in the Splay link.
7. Lift the frame until the hook of the Splay link hooks into the preset Locking pin.
8. Insert the second Locking pin (Safety pin) to secure the frame's Splay link in place.

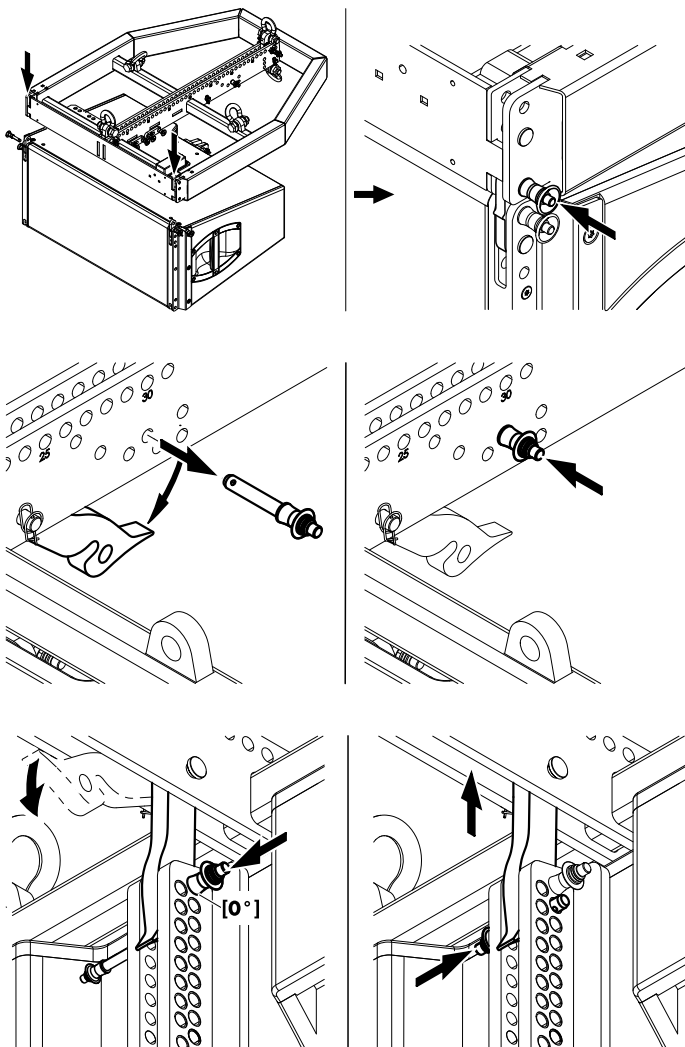

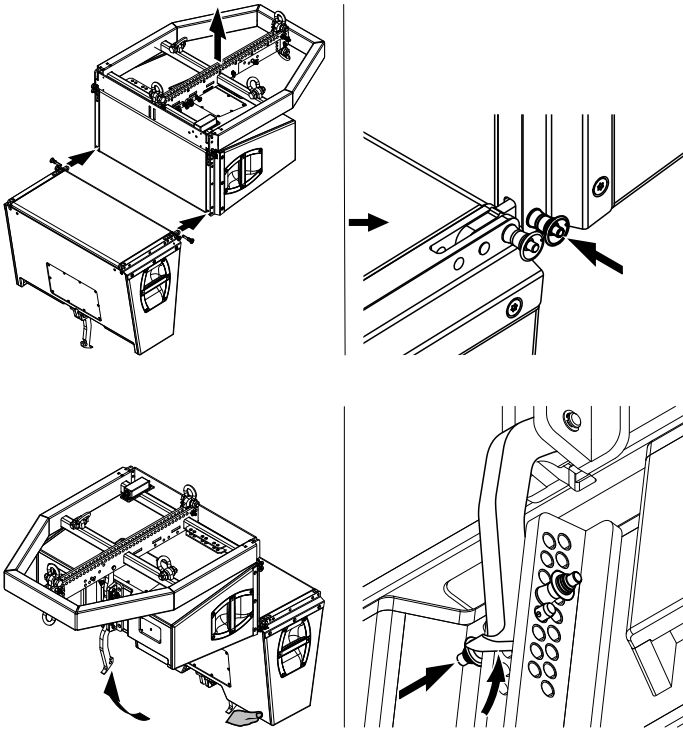

3. Add further cabinets

1. Prepare the Front and Splay links of the next cabinet as described in ⇒ Chapter 2.11. "Cabinet rigging mechanism" on page 19.
2. Preselect the splay angle according to your ArrayCalc simulation.
3. Lift the frame to a suitable working height.
4. Attach the prepared cabinet to the corresponding slots on the front of the upper cabinet.
5. Insert and lock the second Locking pins of the cabinet's Front links on both sides.
6. Raise the bottom cabinet until the Splay link of the upper cabinet has hooked into the preset Locking pin.
7. Release the cabinet and insert the second Locking pin (Safety pin) to secure the Splay link.

To add further cabinets proceed in the same manner until the assembly is completed.

4. Rig the cabling

1. Connect the flying cables and link cables according to the number of amplifier channels and cabinets used.
2. Attach the cable pick.

5. Check the assembly

Before hoisting the array to its operating position recheck the actual status of the entire assembly according to the checklist given in ⇒ Chapter 4. "Safety and system checks" on page 39.

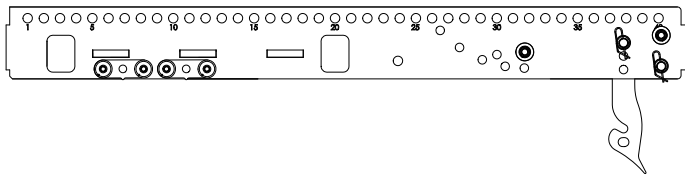

Splay link of the frame – «POSITION V-SUB»

3.2.2. V-SUB Column

Preparations

For this type of setup the Splay link of the frame must be attached to «POSITION V-SUB». Check the position and alter it if necessary as described in ⇒ Chapter 2.9. " Splay link of the frame" ⇒ " Changing the Splay link position" on page 17.

1. Prepare the first cabinet

Prepare the Front links of the first cabinet as described in section ⇒ Chapter 2.11. " Cabinet rigging mechanism" on page 19.

2. Attach the Flying frame to the first cabinet

1. Lower the frame onto the cabinet until the Front links fit into the slots at the front of the frame.
2. Insert the second Locking pins of the cabinet's Front links on both sides.
3. On the rear rigging strand of the cabinet, release both Locking pins.
4. Fold the Splay link into the rigging strand and reinsert the Locking pins.

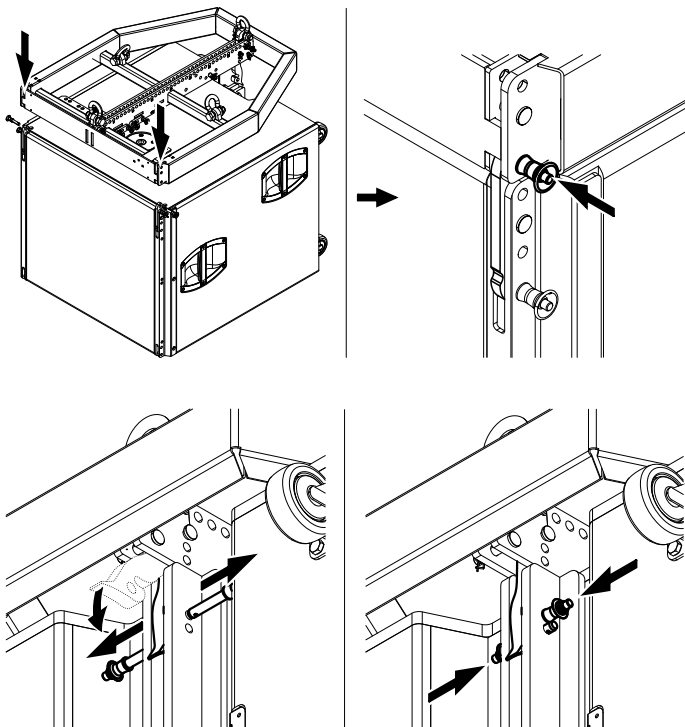

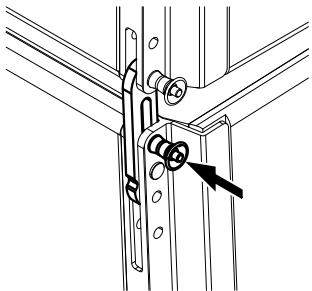
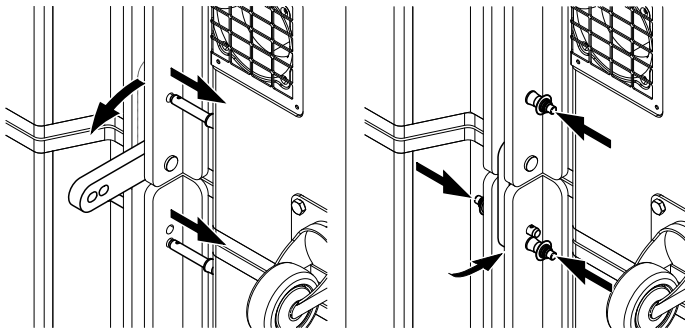
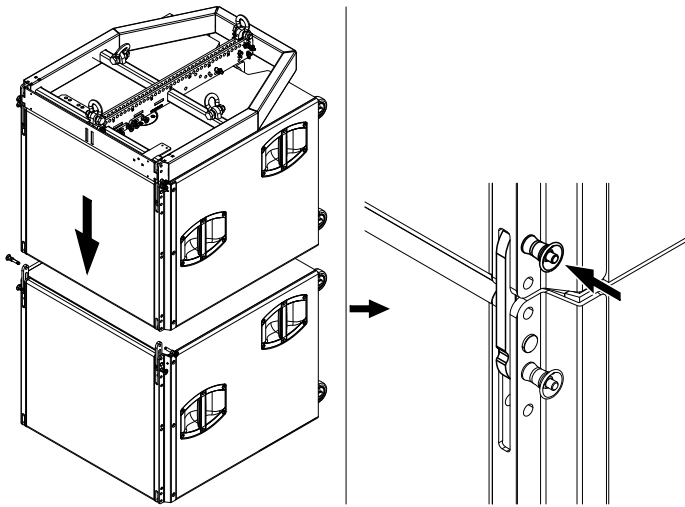

SUB to SUB, 2.5° splay, free

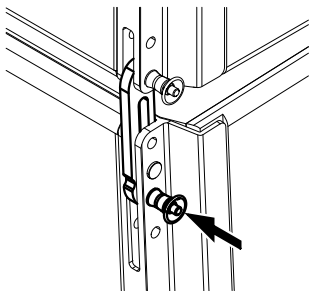

SUB to SUB, 2.5° splay, blocked

3. Add further cabinets

1. Prepare the Front links of the next cabinet as described in section ⇒ Chapter 2.11. " Cabinet rigging mechanism" on page 19.
2. Lift the current assembly to a suitable working height.
3. Position the next cabinet below the assembly.
4. Lower the assembly onto the cabinet until the Front links of the bottom cabinet fit into the slots of the upper cabinet.
5. Insert the second Locking pins of the cabinet's Front links on both sides.
6. On the rear rigging strand, release the Locking pins of both cabinets.
7. Fold out the Rear link of the upper cabinet.
8. Reinsert the Locking pin on the upper cabinet.
9. Fold the Rear link into the rigging strand of the bottom cabinet.
10. Reinsert the two Locking pins on the bottom cabinet.

To add further cabinets, proceed in the same manner until the assembly is completed.

Splay option

The Front links of the SUB cabinets allow for a splay angle of 2.5° between adjacent SUB cabinets. Before hoisting the array, the angle can be set in two ways:

free The second Locking pin of the cabinet's Front link is inserted in the top hole of the front rigging strand as shown in the graphic opposite. This can be done for all cabinets in one step. The angle opens itself as soon as the array is hoisted.

blocked The second Locking pin of each cabinet's Front link is inserted in the second hole cabinet by cabinet during hoisting as shown in the graphic opposite. Due to the design of the Front link mechanism, the Locking pin can be inserted free of load.

4. Rig the cabling

1. Connect the flying cables and link cables according to the number of amplifier channels and cabinets used.
2. Attach the cable pick.

5. Check the assembly

Before hoisting the array to its operating position recheck the actual status of the entire assembly according to the checklist given in ⇒ Chapter 4. "Safety and system checks" on page 39.

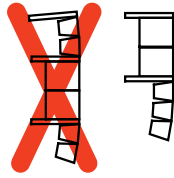

3.2.3. Mixed array

NOTICE!

If SUB cabinets are included in the array, these must always be positioned at the top of the column.

Remarks

For a mixed setup two Flying frames are required. One frame is used for suspension and the second frame acts as an adapter to add V8/V12 cabinets below the SUB cabinets.

Since the first part of the setup is similar to the setup of a flown SUB column as described in , this section only describes the assembly of the second Flying frame below the SUB cabinets.

Preparations

For this type of setup the Splay link of the second frame must be attached to «POSITION V8/V12». Check the position and alter it if necessary as described in ⇒ Chapter 2.9. " Splay link of the frame" ⇒ " Changing the Splay link position" on page 17.

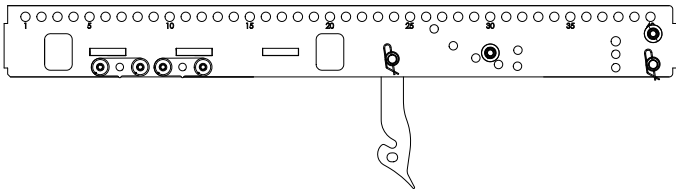

Splay link of the frame – «POSITION V8/V12»

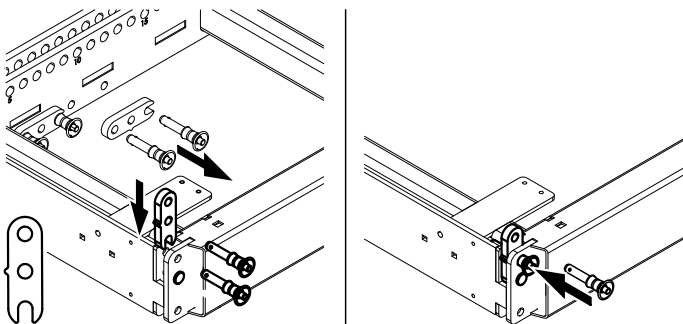

1. Prepare the second Flying frame

To attach the second frame below the SUB cabinets, the two additional Front links of the frame are needed.

1. Remove the additional Front links together with their Locking pins from their park positions on the frame.
2. Attach the additional Front links at the top of the front tracks of the frame and fix them with one Locking pin each.

Note: Observe the direction of attachment as shown in the graphic opposite.

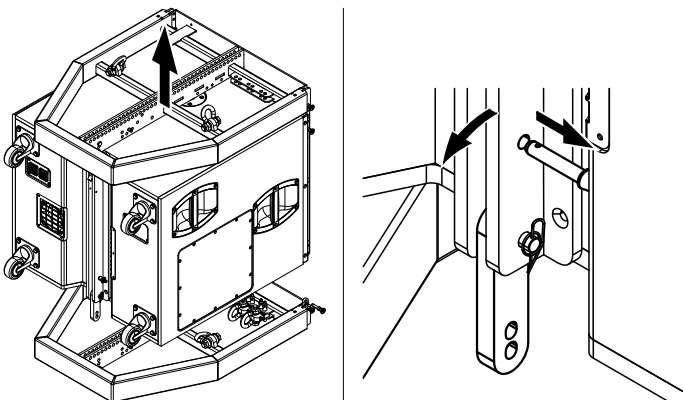

2. Attach the assembly to the frame

1. Lift the assembly to allow the second frame to be positioned below the assembly.
2. Position the frame below the assembly.
3. Fold out the Rear link of the SUB cabinet.

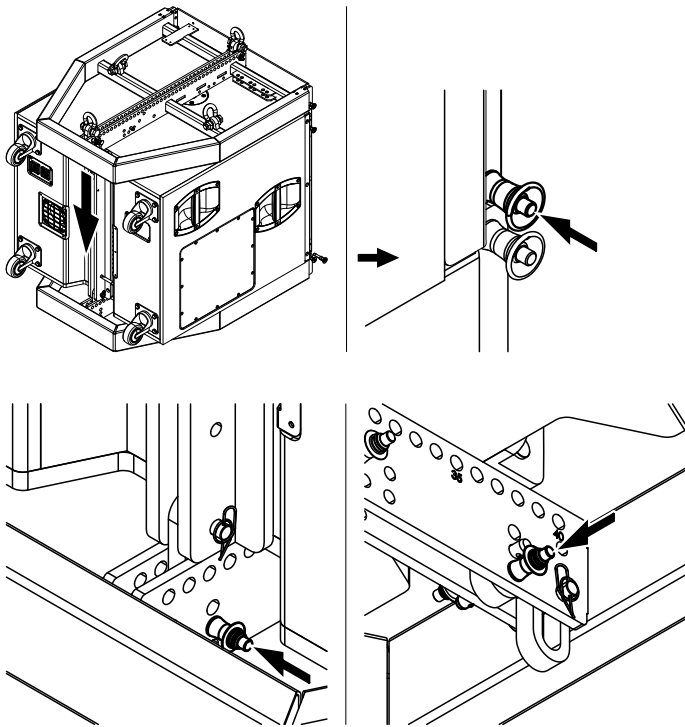

4. Lower the assembly onto the frame until the Front links fit into the slots at the front of the frame and the Rear link fits into the track of the frame's center bar.
5. Insert the second Locking pins of the Front links on both sides.

6. On the rear rigging strand of the cabinet, insert the (first) Locking pin of the cabinet's Rear link to the fixing hole of the frame's center bar.
7. Release the Locking pin of the cable pick and insert it to the second fixing hole of the frame's center bar.

3. Add V8/V12 cabinets below the SUBs

Adding V8/V12 cabinets below the SUBs is similar to the setup of a flown V8/V12 array as described in .

4. Rig the cabling

1. Connect the flying cables and link cables according to the number of amplifier channels and cabinets used.
2. Attach the cable pick.

5. Check the assembly

Before hoisting the array to its operating position recheck the actual status of the entire assembly according to the checklist given in ⇒ Chapter 4. "Safety and system checks" on page 39.

3.3. V Touring cart assembly

The V Touring cart allows for a quick and easy setup of arrays as the entire cabinet assembly stored in the cart can be directly connected to the V Flying frame or mounted below already suspended V8/V12 or V-SUB cabinets.

This type of setup is also very efficient when working space is restricted.

3.3.1. Assembly

Remarks

For the assembly the same general preparations are made as described in .

The setup should always be carried out by two persons.

The rigging procedure described below applies to both touring cart options.

Splay link of the frame

For this type of setup, the Splay link of the frame must be attached to «POSITION V8/V12». Check the position and alter it if necessary as described in ⇒ Chapter 2.9. " Splay link of the frame" ⇒ " Changing the Splay link position" on page 17.

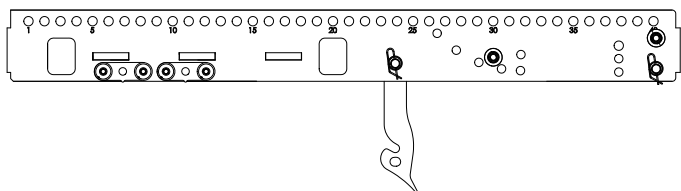

Splay link of the frame – «POSITION V8/V12»

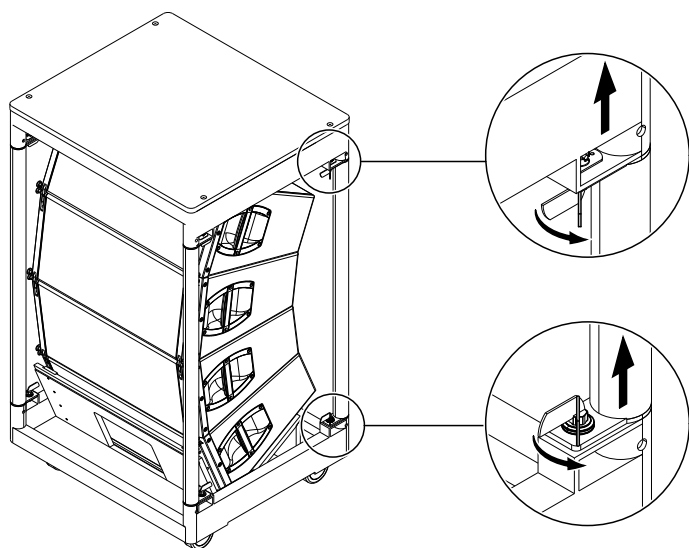

3.3.1.1. Cabinet assembly to Flying frame

1. Prepare the touring cart

1. Move the cart to its assembly position.
2. Unlock the four fasteners (CamLocks) on the top lid and take off the lid.
3. Unlock the four fasteners (CamLocks) on the bottom tray and remove the connecting poles.

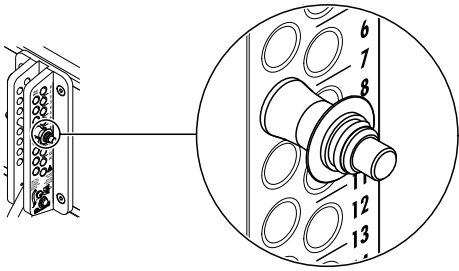

2. Prepare the cabinets

1. On the rear first remove all Locking pins.
2. Preset the splay angles of all cabinets based on your ArrayCalc simulation.

Note: If the cabinet assembly is connected directly to the Flying frame, the splay angle of the first (top) cabinet must be set to **[0°]**.

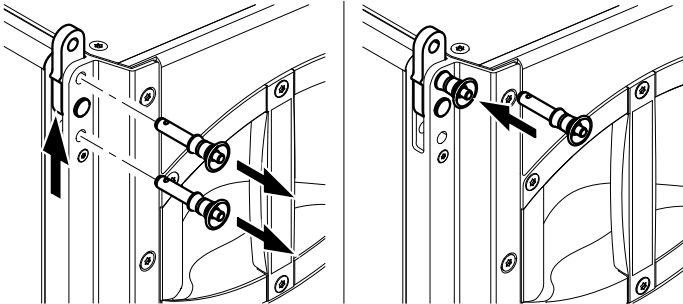

3. On the top cabinet, release both Locking pins and slide out the Front link.
4. Insert and lock one Locking pin to fix the link in place.

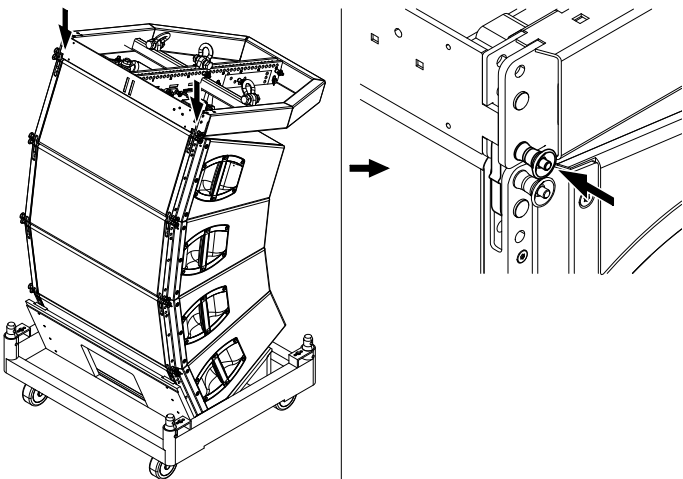

3. Attach the Flying frame

1. Lower the frame onto the first cabinet of the assembly until the Front links fit into the slots at the front of the frame.
2. Insert and lock the second Locking pins of the cabinet's Front links on both sides.

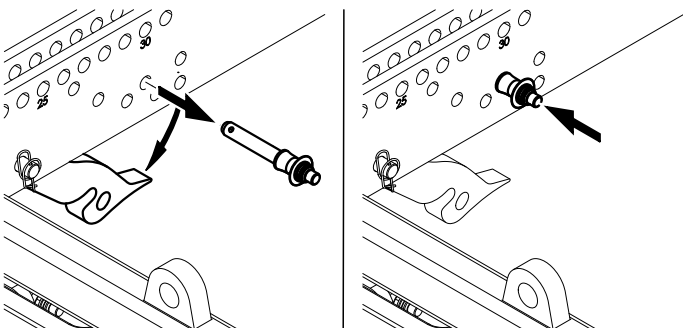

3. Release the Locking pin that keeps the frame's Splay link in its park position.
4. Fold out the Splay link and reinsert the Locking pin.

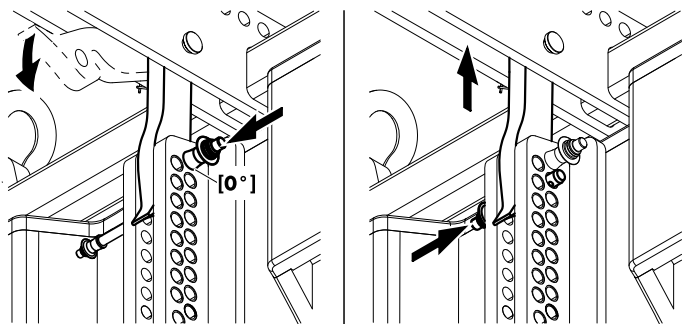

5. On the rear rigging strand of the first cabinet, check the splay angle is set to **[0°]**.
6. Slightly lower the frame and fold in the Splay link into the strand.
7. Lift the frame until the Splay link hooks into the preset Locking pin.
8. Insert and lock the second Locking pin (Safety pin) to secure the Splay link in place.

4. Apply and fix the preset splay angles

The Splay links will be engaged automatically while lifting the assembly.

1. Slowly lift the cabinet assembly out of the cart until all Splay links have hooked into the preset Locking pins.
2. Stop lifting and insert and lock the second Locking pins (Safety pins) to secure the Splay links in place.

Note: In certain cases, the Splay links may not be engaged automatically. In this case, the Splay angles of the cabinets should be applied and fixed in the cart before the assembly is connected to the array. For this purpose, proceed as follows:

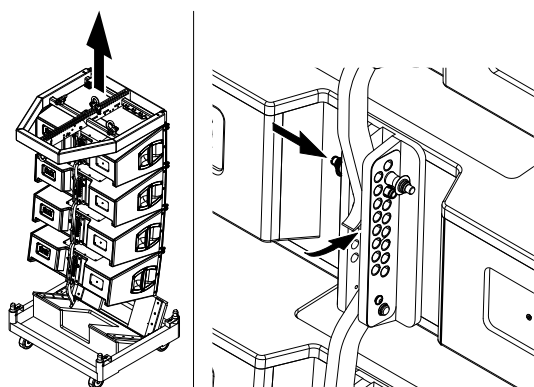

4a. Apply and fix the preset splay angles manually

1. Raise the back of the cabinet until the Splay link has hooked into the preset Locking pin of the bottom cabinet.
2. Hold the cabinet in place and insert the second Locking pin (Safety pin) to fix the Splay link.

To apply and fix the splay angles of further cabinets, proceed in the same manner.

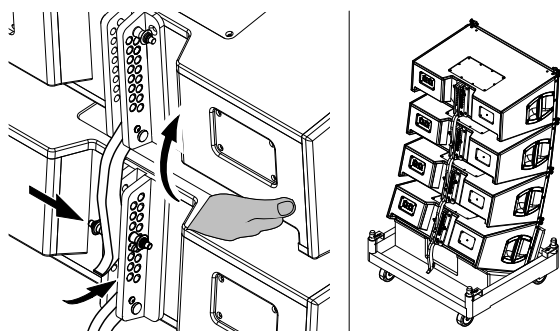

3.3.1.2. Cabinet assembly below V8/V12 cabinets

Preparations

To mount the cabinet assembly below already suspended V8/V12 cabinets, prepare the respective cabinet assembly in the same manner as described in the previous section ⇒ 3.3.1.1. "Cabinet assembly to Flying frame", ⇒ "2. Prepare the cabinets" on page 30.

1. Attach the assembly to the array

1. Lower the array until the Front links of the top cabinet in the cart fit into the slots at the front of the bottom cabinet in the array while a second person secures the cart against moving and tipping over.
2. Insert and lock the second Locking pins of the cabinet's Front links on both sides.

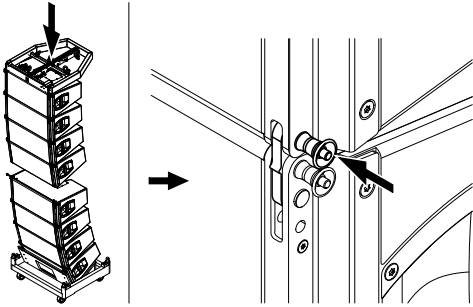

2. Apply and fix the preset splay angles

1. Slowly lift the cabinet assembly out of the cart until all Splay links have hooked into the preset Locking pins.
2. Stop lifting and insert and lock the second Locking pins (Safety pins) to secure the Splay links in place.

Note: If the Splay links are not engaged automatically, proceed in the same manner as described in the previous section ⇒ 3.3.1.1. "Cabinet assembly to Flying frame" ⇒ "4a. Apply and fix the preset splay angles manually" on page 32.

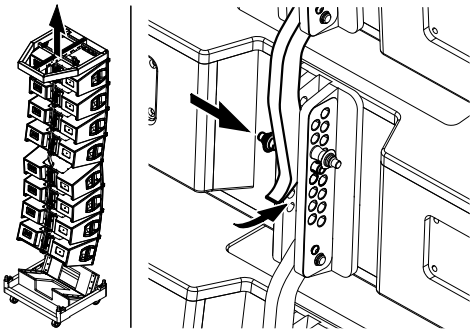

3. Connect the bottom assembly to the Splay link of the upper assembly

1. With two persons raise the entire assembly until the Splay link of the array's bottom cabinet hooks into the preset Locking pin.
2. Slightly lower the assembly to allow the second Locking pin (Safety pin) to be inserted.
3. Insert and lock the second Locking pin (Safety pin) to secure the Splay link in place.

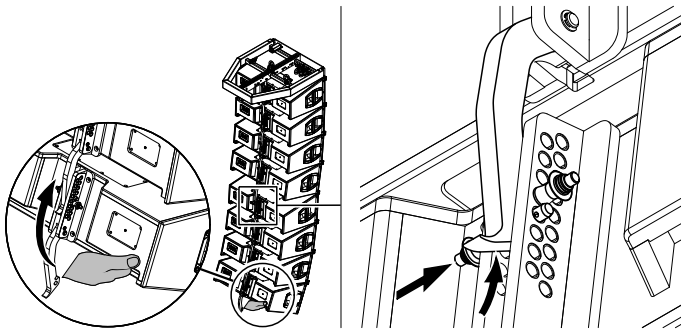

4. Rig the cabling

Connect the flying cables and link cables according to the number of amplifier channels and cabinets used.

5. Check the assembly

Before hoisting the array to its operating position recheck the actual status of the entire assembly according to the checklist given in ⇒ Chapter 4. "Safety and system checks" on page 39.

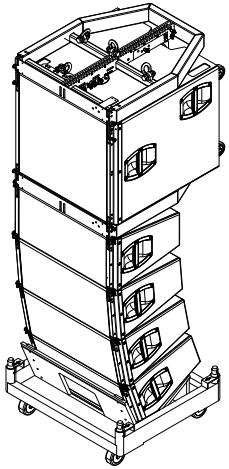

3.3.1.3. Cabinet assembly below V-SUB cabinets

Mounting the cabinet assembly below already suspended V-SUB cabinets is similar to the procedure described in the previous section ⇒ Chapter 3.3.1.2. "Cabinet assembly below V8/V12 cabinets" on page 33.

However, due to the possible size and weight of the suspended SUB assembly, carry out the assembly very carefully and considerably.

We recommend you to apply and fix the splay angles of the TOP cabinets in the cart manually, before attaching the SUB assembly. For this purpose proceed as follows:

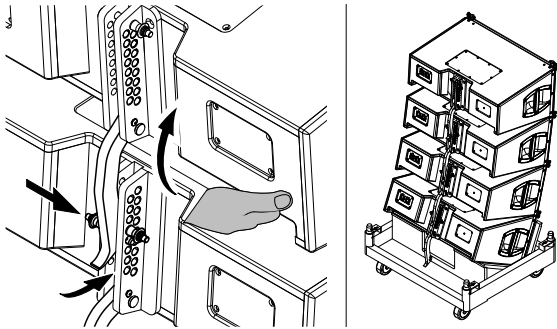

Apply and fix the preset splay angles manually

1. Raise the back of the cabinet until the Splay link has hooked into the preset Locking pin of the bottom cabinet.
2. Hold the cabinet in place and insert the second Locking pin (Safety pin) to fix the Splay link.

To apply and fix the splay angles of further cabinets, proceed in the same manner.

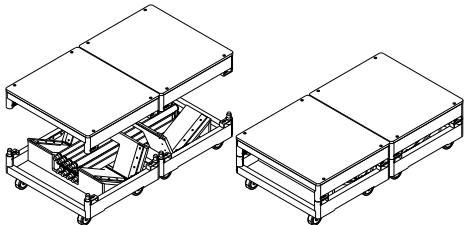

3.3.1.4. Cart storage

The most space-saving way to store the carts during an event is to place the connecting poles into the bottom tray and attach the top lid to the bottom tray.

The conical connectors of the bottom tray will keep the top lid fixed in place.

3.4. Ground stacks



WARNING!

Potential risk of personal injury and/or damage to material!

Always secure ground stacked setups against movement and possible tipping over.

Observe the maximum number of cabinets permitted. This is particularly important when setting up mixed ground stacks.

3.4.1. V8/V12 ground stack

Limitations

A maximum of 8 x TOP cabinets with the V Flying frame serving as ground support are allowed to be set up as ground stack.

Preparations

In this type of setup the V Flying frame is used as ground support.

For this purpose, the Splay link of the frame must be removed and stored in a safe place.

The Locking pin of the Cable pick will be used to fix the vertical aiming of the first TOP cabinet on the Flying frame at a later stage. For this reason, the Cable pick assembly (O-ring) must be attached to hole 35 of the Frame's hole grid.

Proceed as follows:

1. Prepare the Flying frame

To attach the TOP cabinets to the Flying frame, the two additional Front links of the frame are required.

1. Remove the additional Front links together with their Locking pins from the park position on the frame.
2. Attach the additional Front links at the top of the front tracks of the frame and fix them using one Locking pin.
⇒ Observe the direction of attachment as shown in the graphic opposite.

2. Change the position of the Cable pick

1. Release and remove the Locking pin of the Cable pick.
2. Unlock and remove the ring cotter of the fixing bolt.
3. Pull out the fixing bolt and take off the O-ring.
4. Attach the O-ring to its new position (hole 35) and insert the fixing bolt.
5. Reinsert the ring cotter to secure the fixing bolt and ensure the ring cotter is properly locked.

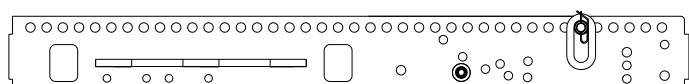

Splay link removed and Cable pick attached to hole 35.

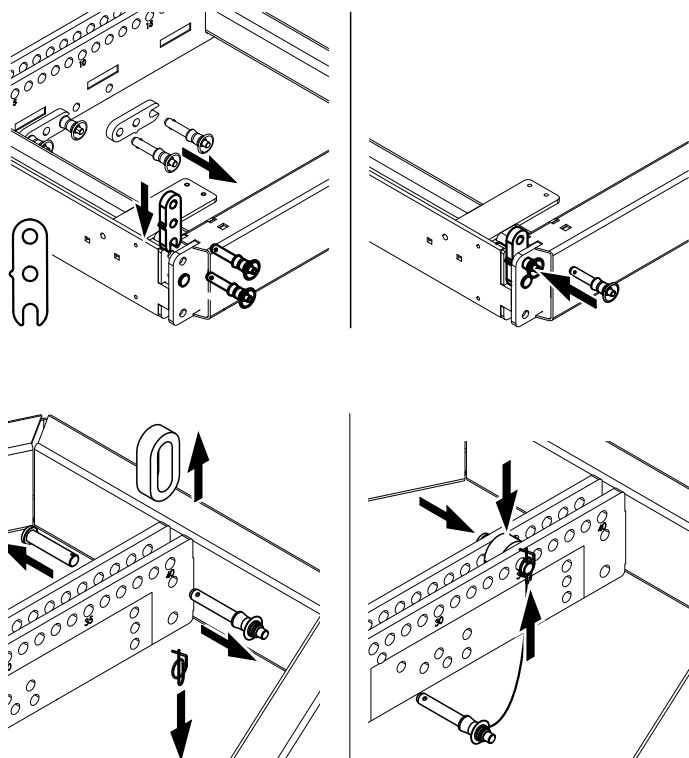

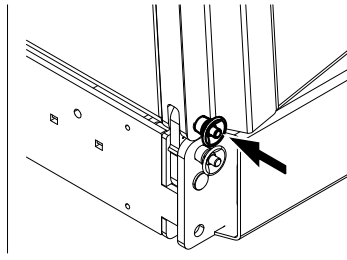
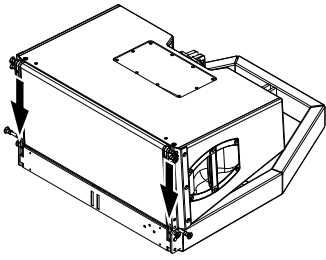

3. Attach the first cabinet to the frame

1. Place the cabinet onto the frame until the additional Front links fit into the slots at the front of the cabinet.
2. Insert the second Locking pins of the additional Front links on both sides.

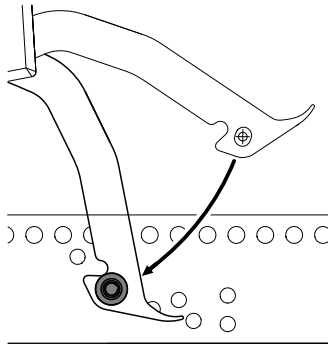
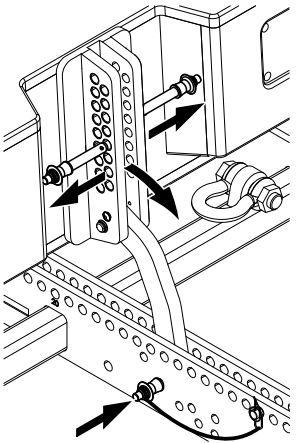

4. Set the vertical aiming of the first cabinet

The hole grid on the Flying frame allows the first cabinet to be set to a fixed vertical angle of -7° , -3.5° , 0° , $+3.5^\circ$ or $+7^\circ$. The hole (drill) of the cabinet's Splay link is used for this purpose. It supports the cabinet and defines the angle setting.

1. Release the Locking pins of the cabinet's Splay link.
2. Fold out and insert the Splay link into the track of the center bar of the frame and align the hole of the link with the desired hole of the frame.
3. Fix the angle of the cabinet using the Locking pin of the Cable pick.

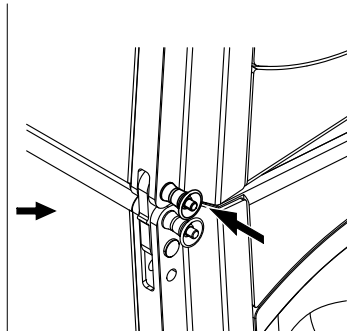
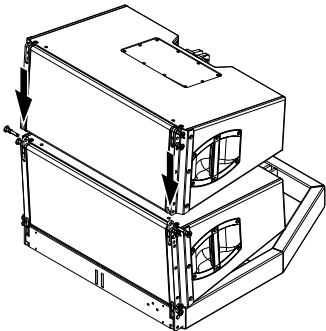

5. Add further cabinets

1. Release the Locking pins of the Front links of the first cabinet.
2. Slide out the Front links and insert one Locking pin each to fix them in place.
3. Attach the next cabinet to the Front links and insert the second Locking pins on both sides.

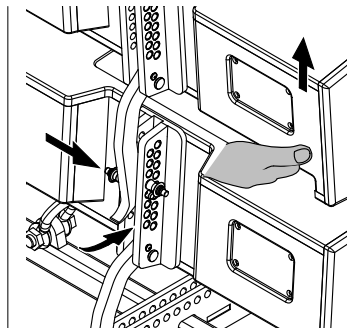
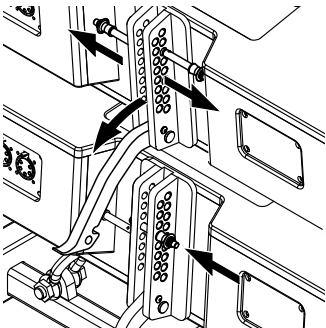

4. At the rear, release both Locking pins of the upper cabinet's Splay link.
5. Preset the desired splay angle on the rear rigging strand of the bottom cabinet using one Locking pin.
6. Fold the Splay link of the upper cabinet into the rigging strand of the bottom cabinet.
7. Raise the upper cabinet until the hook of the Splay link hooks into the preset Locking pin.
8. Hold the cabinet in place and insert the second Locking pin (Safety pin) to fix the Splay link in place.

To add further cabinets, proceed in the same manner until the assembly is completed.

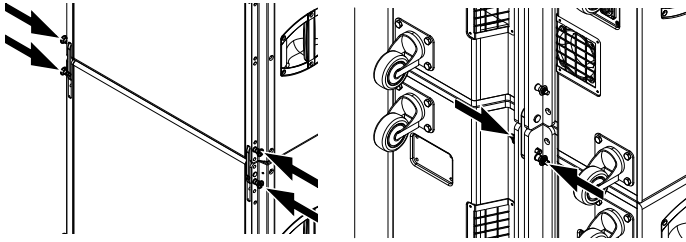

6. Rig the cabling

Connect the flying cables and link cables according to the number of amplifier channels and cabinets used.

7. Check the assembly

Recheck the actual status of the entire assembly according to the checklist given in ⇒ Chapter 4. "Safety and system checks" on page 39.

3.4.2. V-SUB stack

Limitations

A maximum of 8 x SUB cabinets are allowed to be set up as SUB stack.

1. Assembly

Stack the SUB cabinets and interconnect them with their Front and Rear links.

2. Rig the cabling

Connect the flying cables and link cables according to the number of amplifier channels and cabinets used.

3. Check the assembly

Recheck the actual status of the entire assembly according to the checklist given in ⇒ Chapter 4. "Safety and system checks" on page 39.

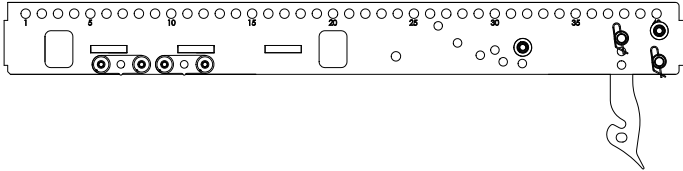

Splay link of the frame – «POSITION V-SUB»

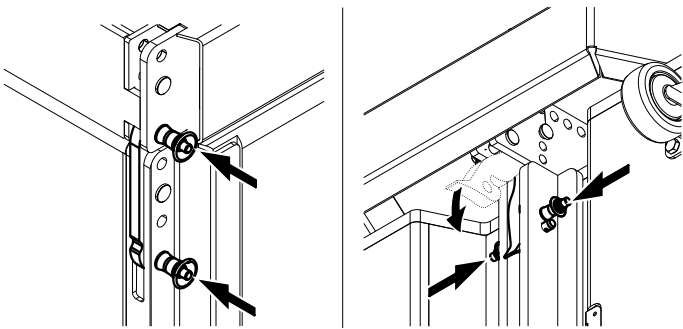

3.4.3. Mixed ground stack

Limitations

A combination of 8 x TOP/SUB cabinets at maximum are allowed to be set up as mixed ground stack.

Preparations

For this type of setup the Splay link of the frame must be attached to «POSITION V-SUB». Check the position and alter it if necessary as described in ⇒ Chapter 2.9. "Splay link of the frame" ⇒ "Changing the Splay link position" on page 17.

1. Assembly

1. Stack the SUB cabinets and interconnect them using their Front and Rear links.
2. Prepare the Front links of the upper SUB cabinet as described in ⇒ Chapter 2.11.1. "Front link mechanism" on page 19.
3. Place the frame onto the cabinet until the Front links fit into the slots at the front of the frame.
4. Insert the second Locking pins of the cabinet's Front links on both sides.
5. On the rear rigging strand of the cabinet, release both Locking pins.
6. Fold the frame's Splay link into the rigging strand and reinsert the Locking pins.

The assembly of the V8/V12 cabinets on top of the frame is carried out in the same manner as described in the previous section ⇒ Chapter 3.4.1. "V8/V12 ground stack" on page 35.

2. Rig the cabling

Connect the flying cables and link cables according to the number of amplifier channels and cabinets used.

3. Check the assembly

Recheck the actual status of the entire assembly according to the checklist given in ⇒ Chapter 4. "Safety and system checks" on page 39.

4. Safety and system checks

Before hoisting the array to its operating position recheck the actual status of the assembly as follows:

Note: When applicable, the same system and safety checks also apply to ground stack assemblies.

4.1. Mechanical setup

- Check the attachment of the Load adapter(s) to the Flying frame and ensure all Locking pins are properly inserted and locked.
- Check the attachment of the secondary safety device at the Flying frame (refer to section ⇒ Chapter 2.8. "Secondary safety" on page 16).
- Check the attachment of the Flying frame(s) to the cabinets and ensure all Locking pins are properly inserted and locked.
- Check the attachment of all Front links on both sides of the cabinets and ensure all Locking pins are properly inserted and locked.
- Check the splay angles and the attachment of the Splay/Rear links on the rear of the cabinets and ensure all Locking pins are properly inserted and locked.
- In "Single pickpoint operation" check the desired total vertical aiming of the entire array using an inclinometer.

4.2. Wiring

- Check the wiring.
If the amplifiers are already wired and powered on, use their System check functions or Channel mute switches and a test signal to check the correct operation and routing of all channels and cabinets.

5. Hoisting and securing the array

5.1. Hoisting the array



WARNING!

Potential risk of personal injury and/or damage to material!

Always ensure that each of the hoists is able to carry the total weight of the array.

When hoisting the array, unpredictable dynamic forces as well as swinging of the array must be taken into account. This may lead to personal injury and/or damage to the rigging components and loudspeaker cabinets.

Ensure that there is nobody directly underneath or in the vicinity of the load who is not involved in the setup.

When all the mechanical adjustments, system checks and safety checks have been made, the array can be hoisted up to its operating position.

When hoisting the array, ensure that the loudspeaker cables do not get caught anywhere. The cables can be strapped together with the motor cable to form a loom while the system is hoisted.

The chain hoist motors must raise the system slowly and evenly so that it does not swing or move from side to side during hoisting.

5.2. Securing the array

When the array is in its final operating position the secondary safety must be applied. A detailed description is given in ⇒ Chapter 2.8. "Secondary safety" on page 16.

6. Derigging

6.1. General

To dismantle any of the assemblies described above, follow the corresponding assembly instructions in reverse order.

The same safety instructions apply.

6.2. Touring cart disassembly

With respect to the touring carts the following procedure is strongly recommended.

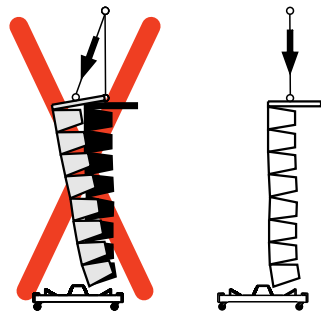

CAUTION!

Potential risk of personal injury and/or damage to material!

In particular make sure that when lowering the array nobody is directly underneath or in the vicinity of the array.

When lowering the array onto the cart **avoid diagonal pull**. This could lead to the potential risk of the array tipping over towards the front.

Depending on the type of surface (arena floor/outdoor field) the cart could suddenly slide out of position and could cause a potentially dangerous situation which may lead to personal injury.

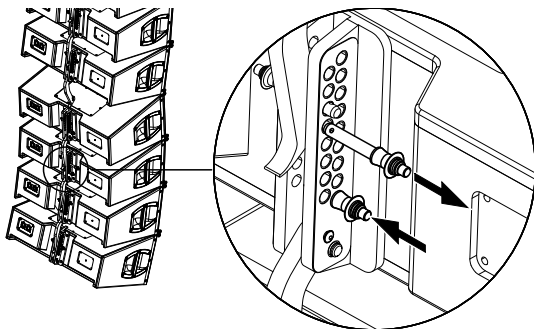
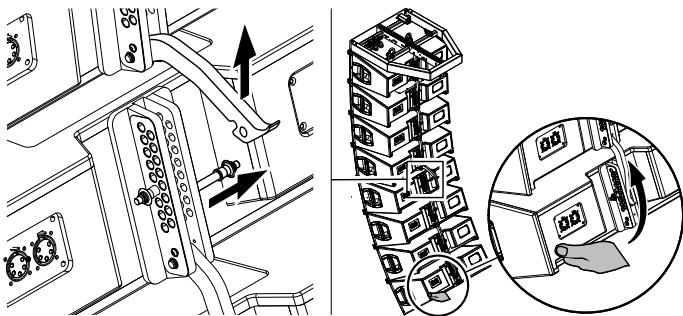

1. Dismantle the first cabinet assembly

1. Lower the array to a suitable working height.
2. Release the Safety pin of the Splay link on the lowest cabinet of the upper assembly.
3. With two persons raise the bottom assembly and fold out the Splay link of the upper assembly.
4. Carefully lower the bottom assembly.
5. Release all Safety pins of the bottom assembly.

Note: To prevent the Safety pins from getting jammed while the assembly is lowered onto the cart, reinsert the Safety pins in one of the remaining holes in the rear rigging strands of the cabinets.

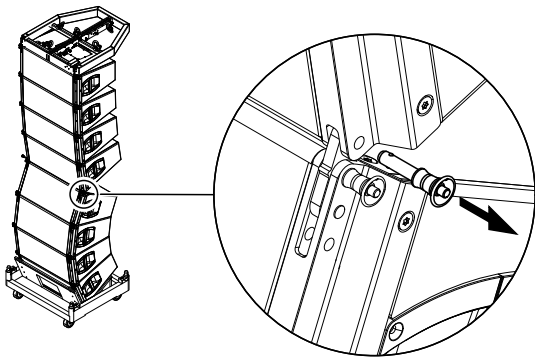

6. Lower the array slowly and evenly onto the cart until the Front links are load-free.
7. Release the Locking pins of the Front links on the top cabinet of the assembly while a second person renders support to prevent the upper suspended assembly from unpredictable swing.
8. Slowly lift the remaining assembly to allow the cart to be turned or moved aside.

Proceed in the same manner until the array is completely dismantled.

2. Reassembling the cart

1. Slide in the Front links of the top cabinet and reinsert the two Locking pins.

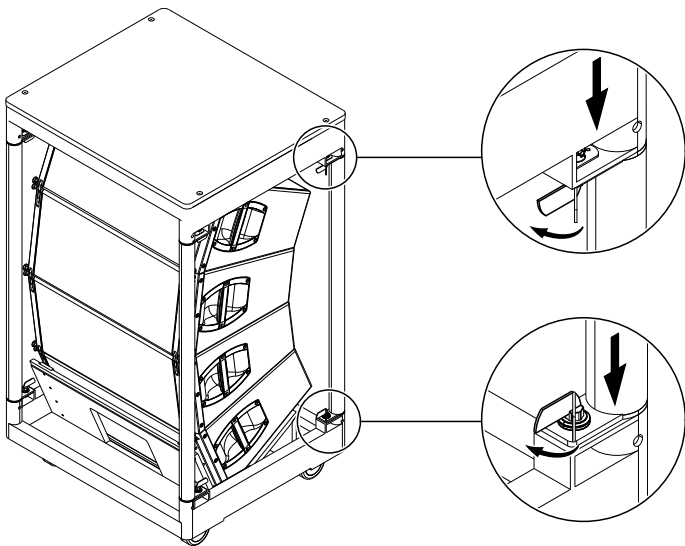
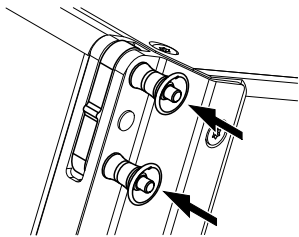

2. Attach the connecting poles to the bottom tray and lock all fasteners (CamLocks).
3. Attach the top lid and lock all fasteners (CamLocks).

Note: The top lids of the touring carts are equipped with additional guiding tracks to fix the cabinet assemblies in place. In conjunction with the E7463 V Touring cart 4 x V8/V12 observe the direction of attachment as shown in the graphic below.

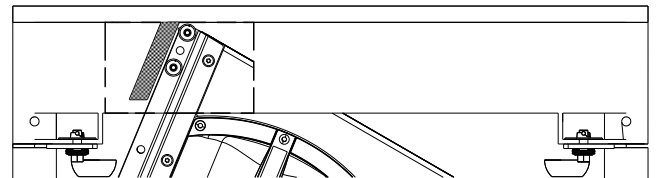

7.1. Transport / Storing

During transport ensure the rigging components are not stressed or damaged by mechanical forces. Use suitable transport cases. We recommend the use of the d&b E7463 or E7464 V Touring cart for this purpose.

Due to their surface treatment the rigging components are temporarily protected against moisture. However, ensure the components are in a dry state while stored or during transport and use.

7.2. Visual and functional inspection



WARNING!

Potential risk of personal injury and/or damage to material

To eliminate the potential risk of accident due to malfunctioning of a component, regularly inspect all system components.

Cabinet enclosure

- Visual inspection of all fitting plates for obvious damage (e.g. cracks or corrosion).
- Visual inspection of the rear rigging strand for obvious damage (e.g. cracks, deformation or corrosion) including all drilled holes of the component.
- Inspection of all fitting plates including front grills to ensure they are securely attached.
- Regularly lubricate the sockets using WD-40® or a similar product.

Front and Splay (Rear) links

Visual inspection regarding deformation and damage (e.g. cracks and corrosion) including all drilled holes of the component.

Locking pins

- Visual inspection for deformation, cracks and corrosion of the component.
- Inspection for missing ball bearings and damage.
- Functional inspection of the release mechanism to ensure it operates properly.
- Regularly lubricate the Locking pins using WD-40® or a similar product.

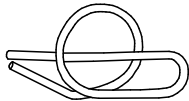
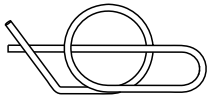

[a]

[b]

Condition of the ring cotter

[a]: Ring cotter OK

[b]: Exchange the ring cotter

Ring cotters

- Visual inspection for obvious damage and deformation.
- Functional test of the locking mechanism as described in ⇒ Chapter 2.4. "Ring cotters" on page 11.
If a ring cotter can no longer be properly fitted to the fixing bolt and locked, it must be exchanged.

Z5380 V Flying frame

- Visual inspection regarding deformation and damage (e.g. cracks and corrosion) including all drilled holes of the component.
- Regularly check the flatness of the Flying frame. For this purpose position the Flying frame on a flat surface and visually check the frame for deformation and/or torsion. For obvious deformation and/or torsion contact d&b audiotechnik for further advice on how to proceed.

Z5381 V Hoist connector chain / Z5382 V Safety chain

Inspection according to the appropriate regulations for lifting devices (EN 818-6:2000). Regularly inspect within a 12 months period. Regularly inspect for cracks within a 36 months period.

7.3. Disposal

When out of use the rigging components must be disposed of in accordance with the national environmental regulations.

Ensure that damaged rigging components are disposed of in a way that they cannot be used again.

8. Manufacturer's declaration

We hereby declare that the equipment designated below is designed and built in the version sold by us in such a way as to comply with the relevant fundamental safety and health criteria of the applicable EC Directive(s). This declaration shall cease to be valid if alterations are made to the equipment without our prior agreement.

This declaration covers:

d&b V-Series loudspeaker cabinets

(With integrated rigging components.)

- Z0515 V8
- Z0516 V12
- Z0518 V-SUB

d&b V-Series rigging components

(Including all additional components such as Load adapter, Front links frame, shackles.)

- Z5380 V Flying frame
- Z5381 V Hoist connector chain
- Z5382 V Safety chainset

National standards and technical specifications applied:

DIN EN ISO 12 100, DIN EN 1050, BGV C1.

Backnang, -2014-08



Frank Bothe,
Head of R&D
d&b audiotechnik GmbH



